

R407C

# ECO COOLER

## AIR COOLED CHILLER

STANDARD MODEL

50Hz

150 kW – 2000 kW

2022

**ECO COOLER**  
AIR CONDITIONER

MULTI STAGE EVAPORATIVE COOLING







Special Public places  
Commercial, Office, Hospital, Restaurant,  
Coffee shop & Etc .



# ECO COOLER

AIR CONDITIONER

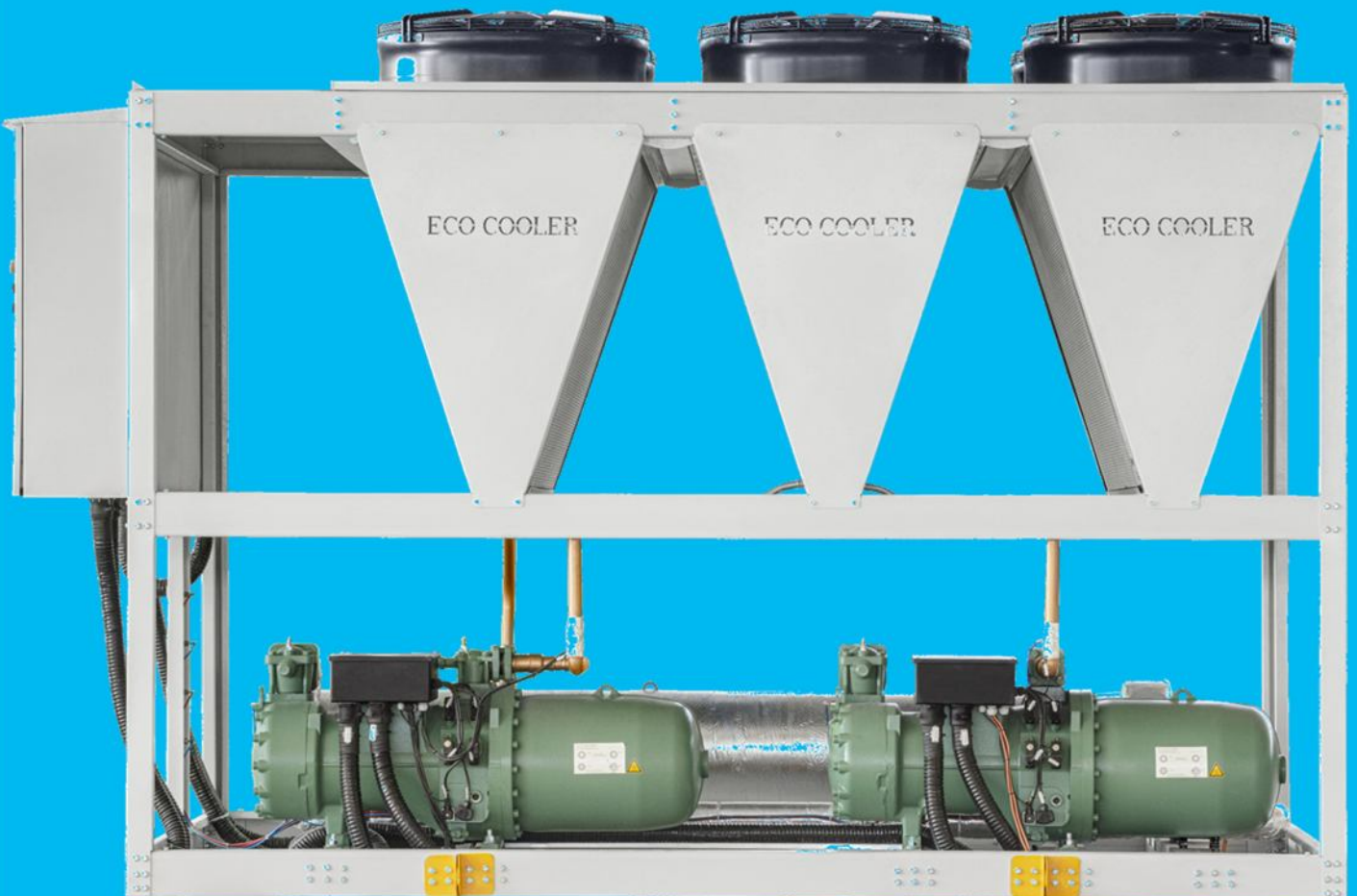



ECO COOLER

## Table of Contents

---

INTRODUCTION	7
NOMENCLATURE	7
FEATURES AND BENEFITS	8
STANDARD SPECIFICATIONS	9
OPTIONAL FEATURES	15
TECHNICAL DATA	16
PERFORMANCE DATA TABLES	19
UNIT DIMENSIONS	23
Typical electrical wiring diagram	35
TYPICAL WIRING DIAGRAM	36

## INTRODUCTION

Eco Cooler connection with customer is permanent and does not lead to sell units. Our motto is making the best environment for people to build a better world to live.

Eco Cooler Air cooled water chillers **EACH** series designed to be suitable for all weather conditions, from cold to moderate to hot climates, the various environment, from residential building to industrial sites with polluted environment. Optimum performance, high efficiency, low power consumption, easy installation and low noise operations are the features of the EACH chillers.

**EACH** series cooling capacities are available from 45 TR (158 kW) to 430 TR (1512 kW). Models are in two categories of STANDARD (for cold and moderate climates) and HIGH EFFICIENT (for hot and tropical climates) conditions.

## NOMENCLATURE

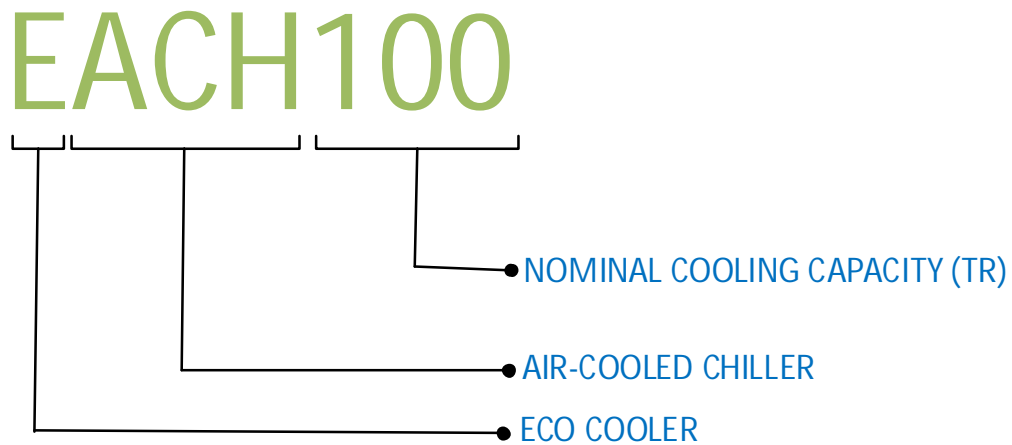

## FEATURES AND BENEFITS

- Optimized energy efficiency both at full and part load conditions
- Low operating sound levels are achieved by the latest compressor and fan design
- Stepped and Stepless screw compressor with professional control system to minimize energy consumption and optimize the unit performance.
- Compact design for minimized installation space and small footprint
- One, two, three or four truly independent refrigerant circuits for outstanding reliability
- Using microchannel technology for condenser with higher corrosion resistance and longer life and 30% refrigerant charge compared to traditional solutions.
- Structure and base in hot-dip galvanized steel with electrostatic powder painting.
- Electrical expansion valve: quickly and precisely adapts to the effective load required.
- Connectable to Building Management Systems (BMS) via MODBUS, BACNet and CANBUS protocols.





## STANDARD SPECIFICATIONS

### SEMI HERMETIC SCREW COMPRESSOR

EACH compressors features mechanical capacity control, which enables very good efficiency and simple system integration. It features mechanical capacity control, which enables very good efficiency and simple system integration. Screw Compressors are equipped to solenoid valve for stepped or stepless capacity control, suction and discharge shut-off valve, oil sight glass, check valve in discharge gas outlet, oil fill/drain service valve, directly flanged on three stage oil separator, robust axial bearings in tandem configuration, internal pressure relief valve as a burst protection and manual lock-out electronic protection system for thermal motor winding temperature, phase reversal, discharge gas temperature protection controls.

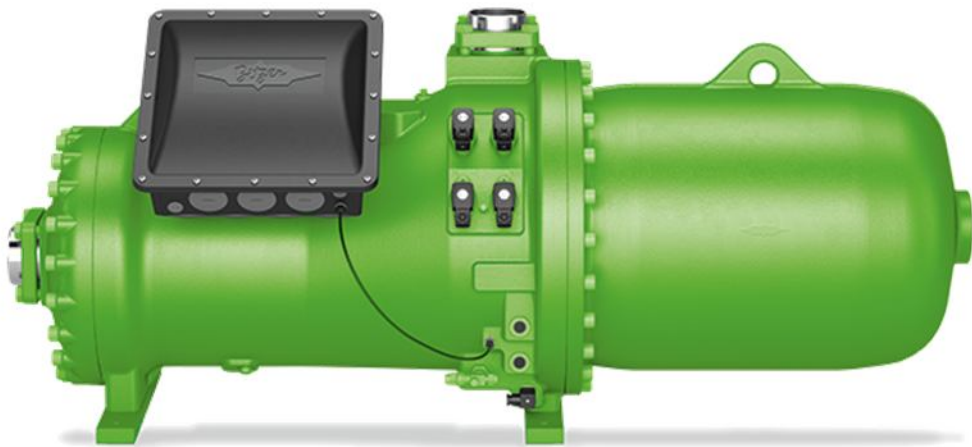

## STANDARD SPECIFICATIONS

### SHELL AND TUBE EVAPORATOR

The evaporator is a high efficiency DX shell & tube heat exchanger design with inner grooved copper tubes roller expanded into the tube sheet. evaporators are tested with a refrigerant side of 30 bars and a water side of 10 bars. Helium leak test is a standard test for evaporators. A guarantee is offered against coolant leak for up to 2 gr/year. Tests are performed at various pressure levels for multi circuit evaporator and prevention of leakage between circuits is guaranteed. Water connections are grooved pipe. Each shell includes a vent, a drain and fittings for temperature control sensors and is insulated with 3/4 inch equal insulation. Evaporator heaters with thermostat are provided to help protect the evaporator from freezing at ambient temperatures down to -29°C.

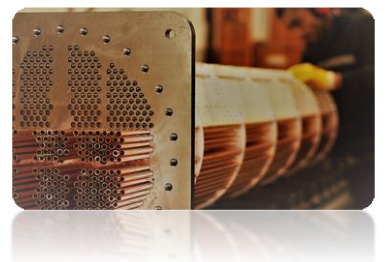
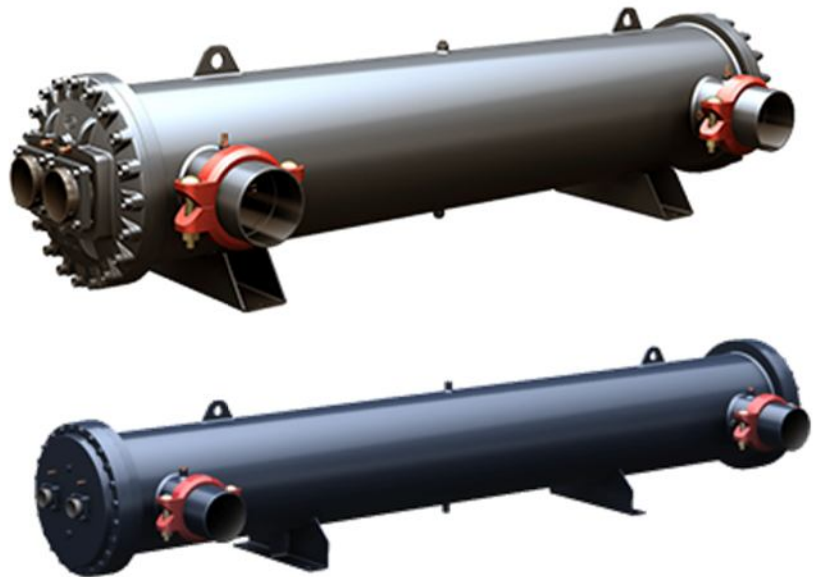

# STANDARD SPECIFICATIONS

## CONDENSERS COIL

The condenser coils are built up microchannel technology. Integral NOCOLOK brazing low contact resistance improve the heat transfer performance perfectly. AL-AL structure without electric potential difference makes high corrosion resistance. The advantages of microchannel condensers over finned-tube coil are:

- Smaller diameter, more tube holes and larger internal surface intensify unit capacity as per volume.
- Small cross sectional area makes low air flow resistance, small eddy area and low noise.
- Parallel arrangement of flat tubes enlarge refrigerant circulation area.
- Adjusting the position and quantity of baffles to adapt to refrigerant phase transition and optimize heat transfer and pressure drop.
- The structure effectively breaks air thermal boundary layer, reducing heat exchanging resistance.
- Waving path makes the contacts longer to intensify heat exchanging.

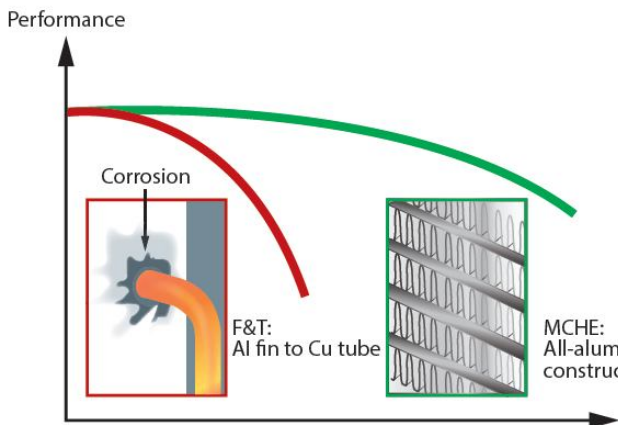
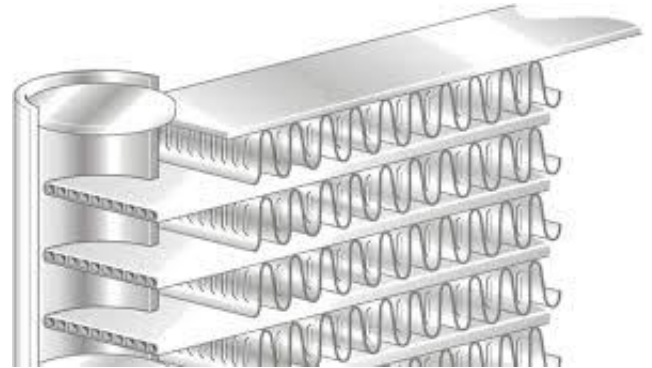
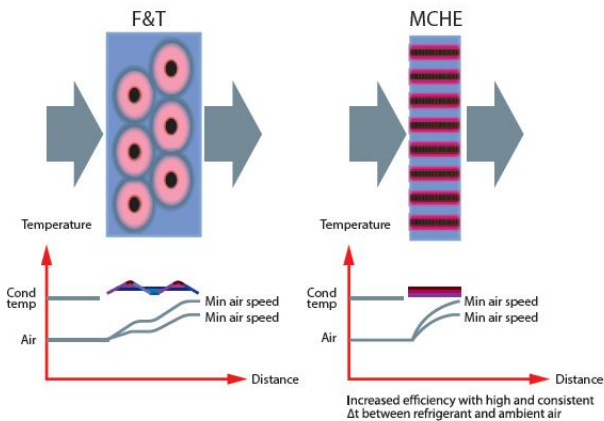

F&T  
dust removal difficult - heat transfer loss  
high risk of damage during cleaning

MCHE  
dust removal easy  
immediate performance recovery

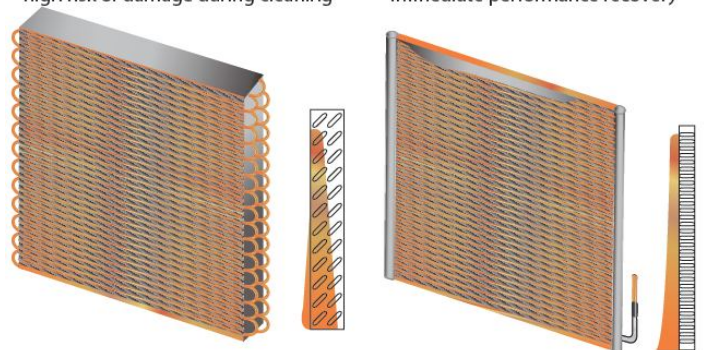



## STANDARD SPECIFICATIONS

### CONDENSER FAN

Direct drive vertical discharge condenser fans are dynamically balanced. Totally enclosed air over motors completely seal the motor windings to prevent exposure to ambient conditions. Three-phase condenser fan motors with permanently lubricated ball bearings and internal thermal overload protection are provided. Improved acoustic performance due to an optimized blade-design external rotor motors comply with protection class IP54. The winding insulation corresponds to insulation class F. Through the use of deep groove ball bearings, closed on both sides, with specially paired grease lubricant, maintenance-free and low-noise operation is guaranteed.



### CONTROL PANEL

Chillers are equipped with a latest version of controller designed to ensure energy saving and unit efficiency. Available functions :

- Monitoring operating parameters including water inlet and outlet temperature, suction and discharge temperature, suction and discharge pressure
- Protecting the system from frosting water
- Stepped or stepless Capacity control
- Controlling Fan start/stop with pressure
- Adjusting Fan speed through controlling inverter (as per request)
- Connection to building Management System (BMS) via MODBUS protocol
- keeping all the faults in the alarm history
- Compressors hour equalization

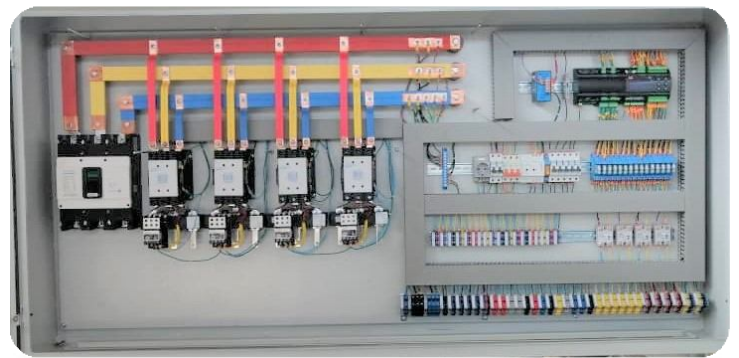

## STANDARD SPECIFICATIONS

### REFRIGERATION PIPE LINE

- INDEPENDENT REFRIGERATION CIRCUIT PER COMPRESSOR
- ELECTRONIC EXPANSION VALVE: Used to regulate the refrigerant flow to the evaporator and maintain a constant superheat and provide capacity required.
- LIQUID LINE REPLACEABLE CORE TYPE FILTER DRIER: Refrigerant circuits are kept free of harmful moisture, sludge, acids and oil contaminating particles by the filter drier.



- LIQUID LINE MOISTURE INDICATOR SIGHT GLASS: Installed in the liquid line. An easy-to-read color indicator shows moisture contents and provides a mean for checking the system refrigerant charge.
- LIQUID, DISCHARGE AND SUCTION LINES SHUT OFF VALVE
- DISCHARGE, SUCTION AND LIQUID LINE PIPES: All pipelines are sized to minimize pressure drop and keep proper velocity ensuring oil return.
- LIQUID INJECTION KIT: For cooling the compressor in high compressor discharge temperature.

## STANDARD SPECIFICATIONS

### ELECTRICAL PANEL

- COMPRESSOR PART WINDING START
- COMPRESSOR IN-BUILT PROTECTION DEVICE
- STARTER: The starter is operated by the control circuit and provides power to the compressor motors. These devices are rated to handle safely both RLA and LRA of motors.
- CRANKCASE HEATERS: Each compressor has immersion type crankcase heater. The compressor crankcase heater is always on when the compressors are de-energized. This protects the system against refrigerant Migration, oil dilution and potential compressor failure.
- HIGH PRESSURE SWITCH: This switch provides an additional safety protection in case of excessive discharge pressure.
- LOW PRESSURE SWITCH: This switch provides an additional safety protection in case of very low suction pressure to avoid water freezing.
- UNIT ON-OFF SWITCH: On Off Switch is provided for manually switching the unit control circuit.
- INDICATOR LIGHTS: LED lights indicates power ON to the units, MENU adjustment and FAULT indications due to trip on safety devices.
- UNDER VOLTAGE AND PHASE PROTECTION: This feature protects the chiller against low incoming voltage as well as single phasing , phase reversal and phase imbalance by de-energizing the control circuit.
- FAN MOTOR CIRCUIT BREAKER: For each pair of condenser fan motor.
- COMPRESSOR CIRCUIT BREAKERS: Protects compressor against overload and short circuit. When tripped, the breaker opens the power supply to the compressor and control circuit through auxiliary contacts. These circuit breakers are provided with thermal adjustable switch for precise overload setting.
- EXTERNAL OVERLOAD RELAY FOR EACH COMPRESSOR
- CONTROL FUSED FOR SHORT CIRCUIT PROTECTION



## OPTIONAL FEATURES



- **WATER FLOW SWITCH:** Paddle type field adjustable flow switch for water cooler circuits, Interlock into safety circuits so that the unit will remain off unit water flow is determine.
- **UNIT MOUNTING SPRING ISOLATORS:** This housed spring assemblies have a neoprene friction pad on the bottom to prevent vibration transmission.
- **COMPRESSOR SILENCER BOX:** reduces the compressor operating noise and keeps the compressor clean.
- **COPPER FINS/TUBES CONDENSER COILS:** For seashore salty corrosive environments.
- **PRE-COATED ALUMINUM FINS CONDENSER COILS (MHG):** For seashore or acid corrosive environments.
- **BUILDING MANAGEMENT SYSTEM (BMS):** MODBUS, BACNET, and CANBUS protocol
- **NON-FUSED MAIN DISCONNECT SWITCHES:** De-energize power supply during servicing/repair works as well as with door interlock.
- **EVAORATOR HEATER TAPE:** Prevent freezing up of water on low ambient.
- **GROUND CURRENT PROTECTION:** Additional protection for compressor in the case of abnormal current leakage.

# TECHNICAL DATA

UNIT MODEL (EACH)		45	50	55	60	70	80	90	100	115	130	140	150
COOLING CAPACITY*	RT	45.4	53.3	60.6	60.6	71.1	80.5	91.8	106.8	120.7	142.4	142.4	159.0
	kW	158.8	186.5	211.9	211.9	249.0	281.9	321.3	373.7	422.3	498.4	498.4	556.6
POWER INPUT (kW)		54.6	60.2	70.9	70.9	80.7	92.4	109.4	120.4	141.9	161.6	161.6	192.8
TOTAL EER (W/W)		2.6	2.8	2.7	2.7	2.8	2.7	2.7	2.8	2.7	2.8	2.8	2.6
COMPRESSOR		<b>Semi Hermetic Compact Screw</b>											
QUANTITY (No.)		1						2					
OIL GRADE		<b>BSE170 Or Equivalent</b>											
OIL CHARGE PER COMPRESSOR (Liter)		14	14	14	14	14	8.5	14	14	14	14	14	14
CAPACITY CONTROL (%) (STEPPED)		<b>100-25</b>											
CONDENSER TYPE		<b>MICRO CHANNEL</b>											
CONDENSER QTY (No.)		6	8	8	8	10	12	12	8	8	10	10	10
TOTAL FACE AREA (m <sup>2</sup> )		6.0	8.0	8.0	8.0	10.0	12.0	12.0	16.0	16.0	20.0	20.0	20.0
CONDENSER FAN		<b>Propeller Direct Driven , 800mm dia , 920 rpm</b>											
FAN QTY (No.)		3	4	4	4	5	6	6	8	8	10	10	10
AIR FLOW RATE (m <sup>3</sup> /h)		67500	90000	90000	90000	112500	135000	135000	180000	180000	225000	225000	225000
MOTOR POWER FAN (kW)		5.7	7.6	7.6	7.6	9.5	11.4	11.4	15.2	15.2	19	19	19
EVAPORATOR		<b>Direct Expansion Shell &amp; Tube</b>											
EVAPORATOR QTY (No.)		1											
WATER FLOW RATE (m <sup>3</sup> /h)		24.7	29.0	33.0	33.0	38.8	43.9	50.0	58.2	65.7	77.6	77.6	86.6
WATER VOLUME PER COOLER (Liter)		34.7	47.5	47.5	47.5	53.6	98.5	93	85.9	139.8	130.8	130.8	121
WATER CONNECTION SIZE (IN /OUT) DIAMETER (mm)		76.2	100	100	100	100	125	125	125	150	150	150	150
EXPANSION VALVE		<b>Electronic</b>											
POWER REQUIREMENT		<b>400V/3PH/50Hz</b>											
REFRIGERATION CIRCUITS (No.)		1						2					
APPROXIMATE WEIGHT (kg)		1116	1263	1273	1273	1433	1706	2103	2375	2458	2735	2735	2782
DIMENSION	HEIGHT (m)	2.59	2.59	2.59	2.59	2.59	2.59	2.59	2.59	2.59	2.59	2.59	2.59
	WIDTH (m)	1.27	1.27	1.27	1.27	1.27	1.27	1.27	2.27	2.27	2.27	2.27	2.27
	LENGTH (m)	2.91	3.88	3.88	3.88	4.85	5.82	5.82	3.88	3.88	4.85	4.85	4.85

\*Capacity rating are based on Standard ARI-550/590 conditions of: 35 °C (95 °F) ambient / 7 °C (44.6 °F) Leaving Chilled Water Temperature / 5 °C (9 °F) Inlet-Outlet Water Temperature Difference / 0.018 m<sup>2</sup>.°C/kW (0.0001 ft<sup>2</sup>. h.°F /Btu) Fouling Factor

# TECHNICAL DATA

UNIT MODEL (EACH)		160	170	180	190	200	220	230	240	250	260	270	280
COOLING CAPACITY*	RT	159.0	173.3	173.3	197.0	197.0	231.9	231.9	268.5	268.5	268.5	268.5	295.2
	kW	556.6	606.5	606.5	689.5	689.5	811.5	811.5	939.9	939.9	939.9	939.9	1033.2
POWER INPUT (kW)		192.8	202.9	202.9	239.1	239.1	268.2	268.2	300.1	300.1	300.1	300.1	329.5
TOTAL EER (W/W)		2.6	2.7	2.7	2.6	2.6	2.8	2.8	2.8	2.8	2.8	2.8	2.8
COMPRESSOR		<b>Semi Hermetic Compact Screw</b>											
QUANTITY (No.)		2											
OIL GRADE		<b>BSE170 Or Equivalent</b>											
OIL CHARGE PER COMPRESSOR (Liter)		14	21	21	21	21	18	18	18	18	18	18	29
CAPACITY CONTROL (%) (STEPPED)		100-25											
CONDENSER TYPE		<b>MICRO CHANNEL</b>											
CONDENSER QTY (No.)		10	12	12	12	12	14	14	16	16	16	16	18
TOTAL FACE AREA (m <sup>2</sup> )		20.0	24.0	24.0	24.0	24.0	28.0	28.0	32.0	32.0	32.0	32.0	36.0
CONDENSER FAN		<b>Propeller Direct Driven , 800mm dia , 920 rpm</b>											
FAN QTY (No.)		10	12	12	12	12	14	14	16	16	16	16	18
AIR FLOW RATE (m <sup>3</sup> /h)		225000	270000	270000	270000	270000	315000	315000	360000	360000	360000	360000	405000
MOTOR POWER FAN (kW)		19.0	22.8	22.8	22.8	22.8	26.6	26.6	30.4	30.4	30.4	30.4	34.2
EVAPORATOR		<b>Direct Expansion Shell &amp; Tube</b>											
EVAPORATOR QTY (No.)		1											
WATER FLOW RATE (m <sup>3</sup> /h)		86.6	94.4	94.4	107.3	107.3	126.3	126.3	146.3	146.3	146.3	146.3	160.8
WATER VOLUME PER COOLER (Liter)		121	227.4	227.4	212.5	212.5	189.7	189.7	224.3	224.3	224.3	224.3	224.3
WATER CONNECTION SIZE (IN/OUT) DIAMETER (mm)		150	200	200	200	200	200	200	200	200	200	200	200
EXPANSION VALVE		<b>Electronic</b>											
POWER REQUIREMENT		<b>400V/3PH/50Hz</b>											
REFRIGERATION CIRCUITS (No.)		2											
APPROXIMATE WEIGHT (kg)		2782	3819	3819	3857	3857	4129	4130	4499	4499	4499	4499	5593
DIMENSION	HEIGHT (m)	2.59	2.59	2.59	2.59	2.59	2.59	2.59	2.59	2.59	2.59	2.59	2.59
	WIDTH (m)	2.27	2.27	2.27	2.27	2.27	2.27	2.27	2.27	2.27	2.27	2.27	2.27
	LENGTH (m)	4.85	5.82	5.82	5.82	5.82	6.79	6.79	7.76	7.76	7.76	7.76	8.73

\*Capacity rating are based on Standard ARI-550/590 conditions of: 35 °C (95 °F) ambient/ 7 °C (44.6 °F) Leaving Chilled Water Temperature / 5 °C (9 °F) Inlet-Outlet Water Temperature Difference/ 0.018 m<sup>2</sup>.°C/kW (0.0001 ft<sup>2</sup>. h.°F/Btu) Fouling Factor



# TECHNICAL DATA

UNIT MODEL (EACH)		300	320	330	340	350	360	380	400	420	430	440	450	480	500	510	530
COOLING CAPACITY*	RT	295.2	344.7	344.7	344.7	344.7	344.7	394.0	394.0	463.7	463.7	463.7	463.7	537.1	537.1	537.1	537.1
	KW	1033.2	1206.4	1206.4	1206.4	1206.4	1206.4	1379.0	1379.0	1623.0	1623.0	1623.0	1623.0	1879.8	1879.8	1879.8	1879.8
POWER INPUT (kW)		329.5	384.0	384.0	384.0	384.0	384.0	478.2	478.2	536.3	536.3	536.3	536.3	600.2	600.2	600.2	600.2
TOTAL EER (W/W)		2.8	2.9	2.9	2.9	2.9	2.9	2.6	2.6	2.8	2.8	2.8	2.8	2.8	2.8	2.8	2.8
COMPRESSOR		Semi Hermetic Compact Screw															
QUANTITY (No.)		2						4									
OIL GRADE		BSE170 Or Equivalent															
OIL CHARGE PER COMPRESSOR (Liter)		29	29	29	29	29	29	21	21	18	18	18	18	18	18	18	18
CAPACITY CONTROL (%) (STEPPED)		100-25															
CONDENSER TYPE		MICRO CHANNEL															
CONDENSER QTY (No.)		18	20	20	20	20	20	24	24	28	28	28	28	32	32	32	32
TOTAL FACE AREA (m <sup>2</sup> )		36	40	40	40	40	40	48	48	56	56	56	56	64	64	64	64
CONDENSER FAN		Propeller Direct Driven , 800mm dia , 920 rpm															
FAN QTY (No.)		18	20	20	20	20	20	24	24	28	28	28	28	32	32	32	32
AIR FLOW RATE (m <sup>3</sup> /h)		405000	450000	450000	450000	450000	450000	540000	540000	630000	630000	630000	630000	720000	720000	720000	720000
MOTOR POWER FAN (kW)		34.2	38	38	38	38	38	45.6	45.6	53.2	53.2	53.2	53.2	60.8	60.8	60.8	60.8
EVAPORATOR		Direct Expansion Shell & Tube															
EVAPORATOR QTY (No.)		1						2									
WATER FLOW RATE (m <sup>3</sup> /h)		160.8	187.8	187.8	187.8	187.8	187.8	214.6	214.6	252.6	252.6	252.6	252.6	292.6	292.6	292.6	292.6
WATER VOLUME PER COOLER (Liter)		224.3	293.5	293.5	293.5	293.5	293.5	212.5	212.5	189.7	189.7	189.7	189.7	224.3	224.3	224.3	224.3
WATER CONNECTION SIZE (IN /OUT) DIAMETER (mm)		200	200	200	200	200	200	200	200	200	200	200	200	200	200	200	200
EXPANSION VALVE		Electronic															
POWER REQUIREMENT		400V/3PH/50Hz															
REFRIGERATION CIRCUITS (No.)		2						4									
APPROXIMATE WEIGHT (kg)		5593	5995	5995	5995	5995	5995	7123	7123	7642	7642	7642	7642	8314	8314	8314	8314
DIMENSION	HEIGHT (m)	2.59	2.59	2.59	2.59	2.59	2.59	2.59	2.59	2.59	2.59	2.59	2.59	2.59	2.59	2.59	2.59
	WIDTH (m)	2.27	2.27	2.27	2.27	2.27	2.27	2.27	2.27	2.27	2.27	2.27	2.27	2.27	2.27	2.27	2.27
	LENGTH (m)	8.73	9.7	9.7	9.7	9.7	9.7	11.64	11.64	13.58	13.58	13.58	13.58	15.52	15.52	15.52	15.52

\*Capacity rating are based on Standard ARI-550/590 conditions of: 35 °C (95 °F) ambient/ 7 °C (44.6 °F) Leaving Chilled Water Temperature / 5 °C (9 °F) Inlet-Outlet Water Temperature Difference/ 0.018 m<sup>2</sup>.°C/kW (0.0001 ft<sup>2</sup>. h.°F /Btu) Fouling Factor

## PERFORMANCE DATA TABLES

LEAVING CHILLED WATER TEMP. (LCWT)	UNIT SIZE	30°C (86°F) AMBIENT TEMPERATURE				
		COOLING CAPACITY		COMP. POWER (kW)	Total EER (W/W)	WATER FLOW (m <sup>3</sup> /h)
		RT	kW			
7°C	EACH-45	49	171.6	50.2	3.1	26.7
	EACH-50	57.3	200.7	57.2	3.1	31.2
	EACH-55	65.4	229	65.3	3.1	35.7
	EACH-60	65.4	229	65.3	3.1	35.7
	EACH-70	76.2	266.6	75.5	3.1	41.5
	EACH-80	86.1	301.3	87	3.1	46.9
	EACH-90	99.3	347.5	100.5	3.1	54.1
	EACH-100	114.8	401.7	114.5	3.1	62.5
	EACH-115	130.3	456	130.5	3.1	71
	EACH-130	152.6	534.1	151	3.1	83.1
	EACH-140	152.6	534.1	151	3.1	83.1
	EACH-150	171.4	599.9	176.4	3.1	93.4
	EACH-160	171.4	599.9	176.4	3.1	93.4
	EACH-170	185.1	648	186.6	3.1	100.9
	EACH-180	185.1	648	186.6	3.1	100.9
	EACH-190	211.4	739.8	217	3.1	115.2
	EACH-200	211.4	739.8	217	3.1	115.2
	EACH-220	247.2	865.4	243	3.2	134.7
	EACH-230	247.2	865.4	243	3.2	134.7
	EACH-240	286.5	1002.7	272.6	3.3	156.1
	EACH-250	286.5	1002.7	272.6	3.3	156.1
	EACH-260	286.5	1002.7	272.6	3.3	156.1
	EACH-270	286.5	1002.7	272.6	3.3	156.1
	EACH-280	316.4	1107.4	301	3.3	172.4
	EACH-300	316.4	1107.4	301	3.3	172.4
	EACH-320	367.5	1286.3	353.6	3.3	200.2
	EACH-330	367.5	1286.3	353.6	3.3	200.2
	EACH-340	367.5	1286.3	353.6	3.3	200.2
	EACH-350	367.5	1286.3	353.6	3.3	200.2
	EACH-360	367.5	1286.3	353.6	3.3	200.2
EACH-380	422.8	1479.7	433.9	3.1	230.3	
EACH-400	422.8	1479.7	433.9	3.1	230.3	
EACH-420	494.5	1730.8	485.9	3.2	269.4	
EACH-430	494.5	1730.8	485.9	3.2	269.4	
EACH-440	494.5	1730.8	485.9	3.2	269.4	
EACH-450	494.5	1730.8	485.9	3.2	269.4	
EACH-480	573	2005.5	545.2	3.3	312.2	
EACH-500	573	2005.5	545.2	3.3	312.2	
EACH-510	573	2005.5	545.2	3.3	312.2	
EACH-530	573	2005.5	545.2	3.3	312.2	

1- ECHA Chillers are rated based on Standard ARI-550/590-98 conditions of: 5 °C (9 °F) Inlet/Outlet Water Temperature Difference and 0.018 m<sup>2</sup>.°C/kW (0.0001 ft<sup>2</sup>. h.°F /Btu) Fouling Factor

2- Direct interpolation is permissible. Do not extrapolate.

3- Energy Efficiency Ratio (EER) is for the overall unit, refer to electrical data for fan power input.

## PERFORMANCE DATA TABLES

LEAVING CHILLED WATER TEMP. (LCWT)	UNIT SIZE	35°C (95°F) AMBIENT TEMPERATURE				
		COOLING CAPACITY		COMP. POWER (kW)	Total EER (W/W)	WATER FLOW (m <sup>3</sup> /h)
		RT	kW			
7°C	EACH-45	45.4	158.8	54.6	2.6	24.7
	EACH-50	53.3	186.5	60.2	2.8	29
	EACH-55	60.6	211.9	70.9	2.7	33
	EACH-60	60.6	211.9	70.9	2.7	33
	EACH-70	71.1	249	80.7	2.8	38.8
	EACH-80	80.5	281.9	92.4	2.7	43.9
	EACH-90	91.8	321.3	109.4	2.7	50
	EACH-100	106.8	373.7	120.4	2.8	58.2
	EACH-115	120.7	422.3	141.9	2.7	65.7
	EACH-130	142.4	498.4	161.6	2.8	77.6
	EACH-140	142.4	498.4	161.6	2.8	77.6
	EACH-150	159	556.6	192.8	2.6	86.6
	EACH-160	159	556.6	192.8	2.6	86.6
	EACH-170	173.3	606.5	202.9	2.7	94.4
	EACH-180	173.3	606.5	202.9	2.7	94.4
	EACH-190	197	689.5	239.1	2.6	107.3
	EACH-200	197	689.5	239.1	2.6	107.3
	EACH-220	231.9	811.5	268.2	2.8	126.3
	EACH-230	231.9	811.5	268.2	2.8	126.3
	EACH-240	268.5	939.9	300.1	2.8	146.3
	EACH-250	268.5	939.9	300.1	2.8	146.3
	EACH-260	268.5	939.9	300.1	2.8	146.3
	EACH-270	268.5	939.9	300.1	2.8	146.3
	EACH-280	295.2	1033.2	329.5	2.8	160.8
	EACH-300	295.2	1033.2	329.5	2.8	160.8
	EACH-320	344.7	1206.4	384	2.9	187.8
	EACH-330	344.7	1206.4	384	2.9	187.8
	EACH-340	344.7	1206.4	384	2.9	187.8
	EACH-350	344.7	1206.4	384	2.9	187.8
	EACH-360	344.7	1206.4	384	2.9	187.8
EACH-380	394	1379	478.2	2.6	214.6	
EACH-400	394	1379	478.2	2.6	214.6	
EACH-420	463.7	1623	536.3	2.8	252.6	
EACH-430	463.7	1623	536.3	2.8	252.6	
EACH-440	463.7	1623	536.3	2.8	252.6	
EACH-450	463.7	1623	536.3	2.8	252.6	
EACH-480	537.1	1879.8	600.2	2.8	292.6	
EACH-500	537.1	1879.8	600.2	2.8	292.6	
EACH-510	537.1	1879.8	600.2	2.8	292.6	
EACH-530	537.1	1879.8	600.2	2.8	292.6	

1- ECHA Chillers are rated based on Standard ARI-550/590-98 conditions of: 5 °C (9 °F) Inlet/Outlet Water Temperature Difference and 0.018 m<sup>2</sup>.°C/kW (0.0001 ft<sup>2</sup>. h.°F /Btu) Fouling Factor

2- Direct interpolation is permissible. Do not extrapolate.

3- Energy Efficiency Ratio (EER) is for the overall unit, refer to electrical data for fan power input.

## PERFORMANCE DATA TABLES

LEAVING CHILLED WATER TEMP. (LCWT)	UNIT SIZE	40°C (104°F) AMBIENT TEMPERATURE				
		COOLING CAPACITY		COMP. POWER (kW)	Total EER (W/W)	WATER FLOW (m <sup>3</sup> /h)
		RT	kW			
7°C	EACH-45	41.7	145.9	59.4	2.2	22.7
	EACH-50	48.9	171.1	64.8	2.4	26.6
	EACH-55	55.6	194.7	77.4	2.3	30.3
	EACH-60	55.6	194.7	77.4	2.3	30.3
	EACH-70	65.7	230.1	87.7	2.4	35.8
	EACH-80	74.2	259.8	100.8	2.3	40.4
	EACH-90	84.4	295.5	119.1	2.3	46
	EACH-100	98	343.2	129.8	2.4	53.4
	EACH-115	111	388.4	154.7	2.3	60.5
	EACH-130	131.6	460.6	175.4	2.4	71.7
	EACH-140	131.6	460.6	175.4	2.4	71.7
	EACH-150	146.7	513.6	211	2.2	79.9
	EACH-160	146.7	513.6	211	2.2	79.9
	EACH-170	160.5	561.8	223.9	2.3	87.5
	EACH-180	160.5	561.8	223.9	2.3	87.5
	EACH-190	182.3	638	263.4	2.2	99.3
	EACH-200	182.3	638	263.4	2.2	99.3
	EACH-220	0	0	0	0	0
	EACH-230	0	0	0	0	0
	EACH-240	0	0	0	0	0
	EACH-250	0	0	0	0	0
	EACH-260	0	0	0	0	0
	EACH-270	0	0	0	0	0
	EACH-280	273.8	958.2	360.6	2.4	149.2
	EACH-300	273.8	958.2	360.6	2.4	149.2
	EACH-320	321.7	1126.1	417.8	2.5	175.3
	EACH-330	321.7	1126.1	417.8	2.5	175.3
	EACH-340	321.7	1126.1	417.8	2.5	175.3
	EACH-350	321.7	1126.1	417.8	2.5	175.3
	EACH-360	321.7	1126.1	417.8	2.5	175.3
	EACH-380	364.6	1276	526.7	2.2	198.6
	EACH-400	364.6	1276	526.7	2.2	198.6
	EACH-420	0	0	0	0	0
EACH-430	0	0	0	0	0	
EACH-440	0	0	0	0	0	
EACH-450	0	0	0	0	0	
EACH-480	0	0	0	0	0	
EACH-500	0	0	0	0	0	
EACH-510	0	0	0	0	0	
EACH-530	0	0	0	0	0	

1- ECHA Chillers are rated based on Standard ARI-550/590-98 conditions of: 5 °C (9 °F) Inlet/Outlet Water Temperature Difference and 0.018 m<sup>2</sup>.°C/kW (0.0001 ft<sup>2</sup>. h.°F /Btu) Fouling Factor

2- Direct interpolation is permissible. Do not extrapolate.

3- Energy Efficiency Ratio (EER) is for the overall unit, refer to electrical data for fan power input.



## PERFORMANCE DATA TABLES

LEAVING CHILLED WATER TEMP. (LCWT)	UNIT SIZE	42°C (107.6°F) AMBIENT TEMPERATURE				
		COOLING CAPACITY		COMP. POWER (kW)	Total EER (W/W)	WATER FLOW (m³/h)
		RT	kW			
7°C	EACH-45	40.3	140.9	61.4	2.1	21.9
	EACH-50	47.2	165.3	66.7	2.2	25.7
	EACH-55	53.7	188.1	80	2.1	29.3
	EACH-60	53.7	188.1	80	2.1	29.3
	EACH-70	63.7	222.8	90.5	2.2	34.7
	EACH-80	71.8	251.4	104.1	2.2	39.1
	EACH-90	81.5	285.4	123.1	2.1	44.4
	EACH-100	94.7	331.5	133.5	2.2	51.6
	EACH-115	107.2	375	160	2.1	58.4
	EACH-130	127.4	445.9	181	2.2	69.4
	EACH-140	127.4	445.9	181	2.2	69.4
	EACH-150	141.8	496.3	218.9	2.1	77.2
	EACH-160	141.8	496.3	218.9	2.1	77.2
	EACH-170	155.5	544.4	232.4	2.1	84.7
	EACH-180	155.5	544.4	232.4	2.1	84.7
	EACH-190	176.4	617.3	274	2.1	96.1
	EACH-200	176.4	617.3	274	2.1	96.1
	EACH-220	0	0	0	0	0
	EACH-230	0	0	0	0	0
	EACH-240	0	0	0	0	0
	EACH-250	0	0	0	0	0
	EACH-260	0	0	0	0	0
	EACH-270	0	0	0	0	0
	EACH-280	265.5	929.3	373.8	2.3	144.6
	EACH-300	265.5	929.3	373.8	2.3	144.6
	EACH-320	313.7	1098	430.2	2.3	170.9
	EACH-330	313.7	1098	430.2	2.3	170.9
	EACH-340	313.7	1098	430.2	2.3	170.9
	EACH-350	313.7	1098	430.2	2.3	170.9
	EACH-360	313.7	1098	430.2	2.3	170.9
	EACH-380	353.3	1236.5	547	2.1	192.5
	EACH-400	353.3	1236.5	547	2.1	192.5
	EACH-420	0	0	0	0	0
EACH-430	0	0	0	0	0	
EACH-440	0	0	0	0	0	
EACH-450	0	0	0	0	0	
EACH-480	0	0	0	0	0	
EACH-500	0	0	0	0	0	
EACH-510	0	0	0	0	0	
EACH-530	0	0	0	0	0	

1- ECHA Chillers are rated based on Standard ARI-550/590-98 conditions of: 5 °C (9 °F) Inlet/Outlet Water Temperature Difference and 0.018 m².°C/kW (0.0001 ft². h.°F /Btu) Fouling Factor

2- Direct interpolation is permissible. Do not extrapolate.

3- Energy Efficiency Ratio (EER) is for the overall unit, refer to electrical data for fan power input.

# UNIT DIMENSIONS

EACH 45-50-55-60

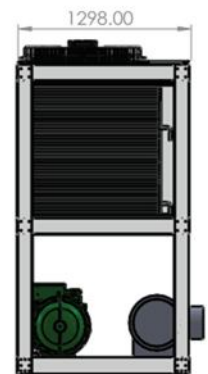
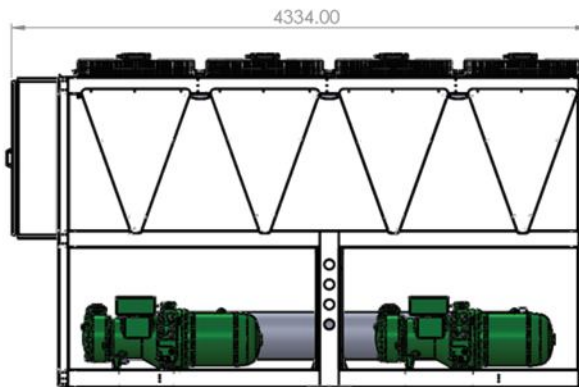
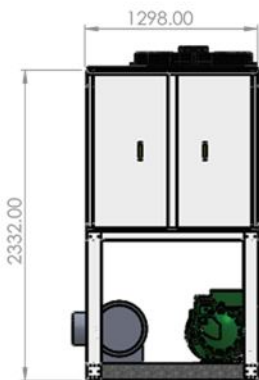
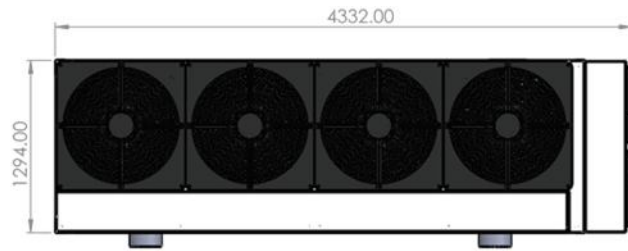
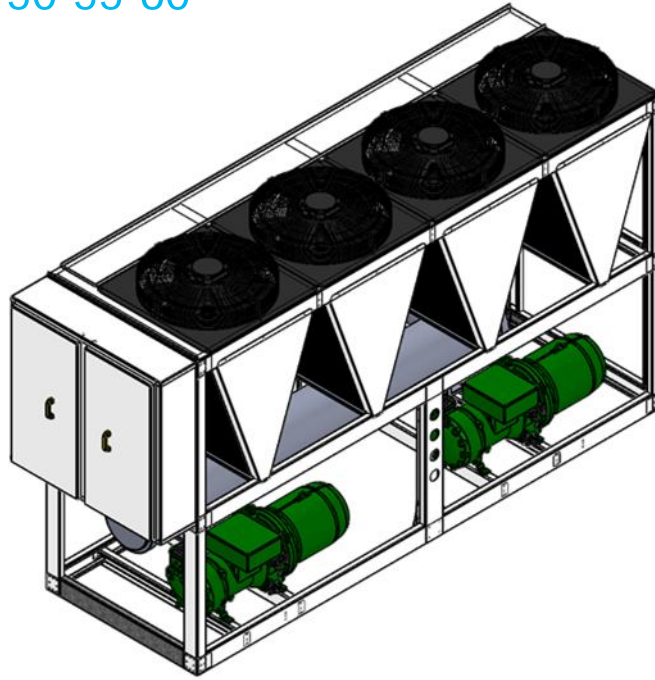

# UNIT DIMENSIONS

EACH 70

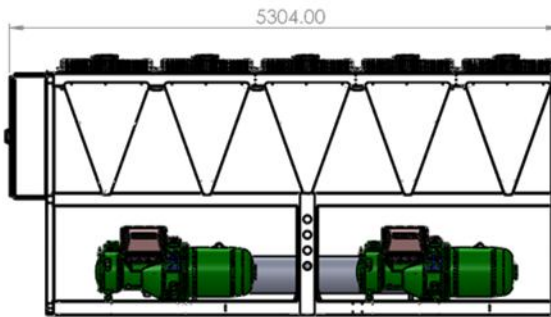
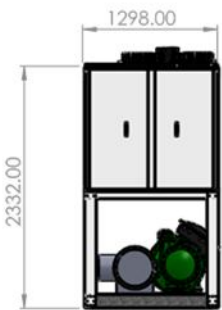
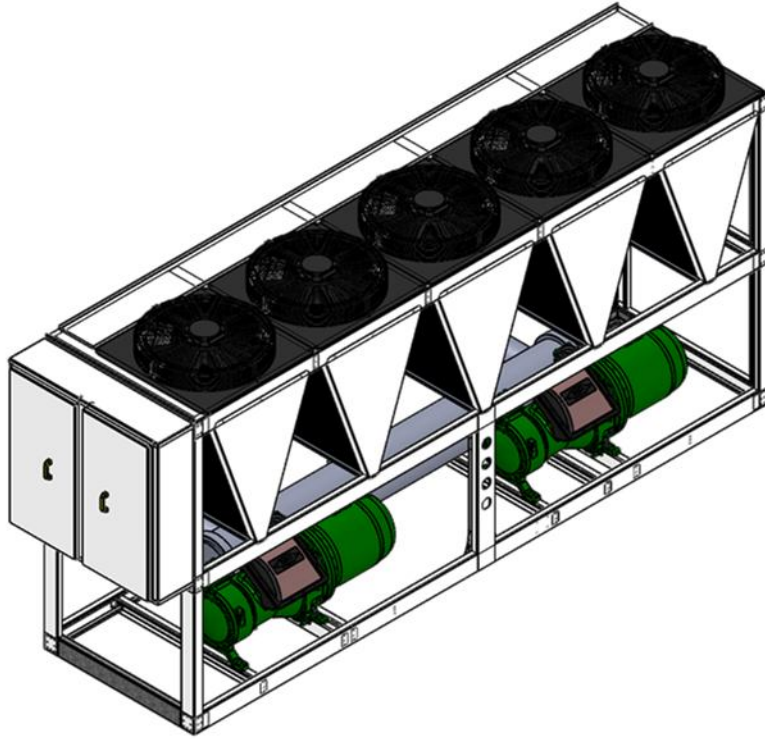

# UNIT DIMENSIONS

EACH 80

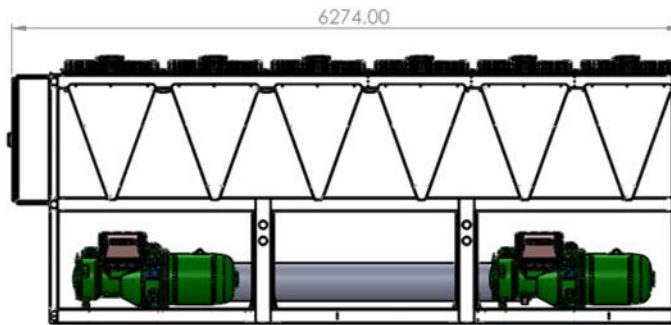
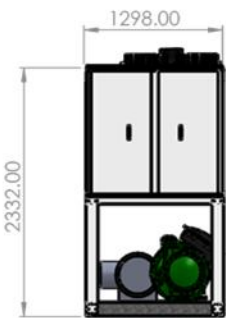
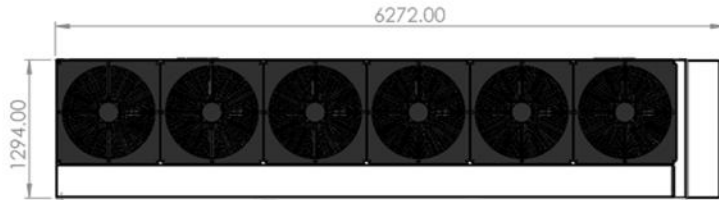
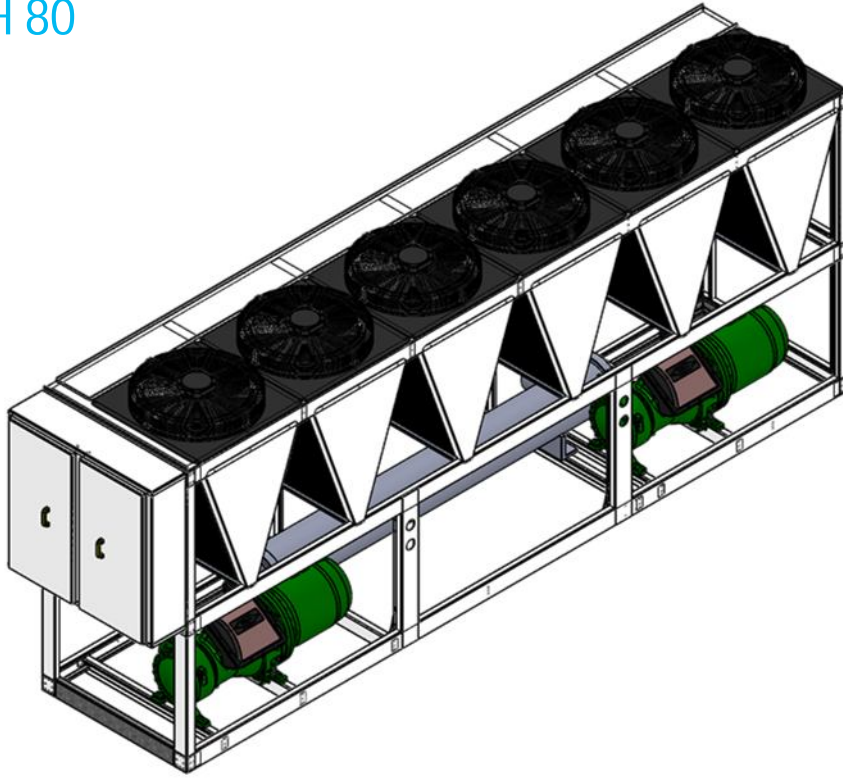



# UNIT DIMENSIONS

EACH 90-100-115

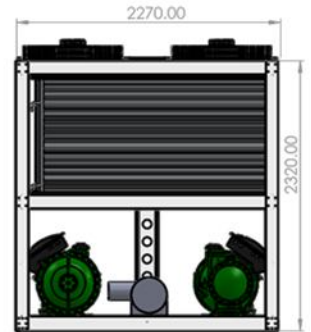
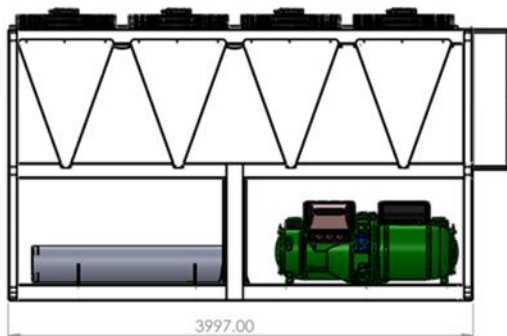
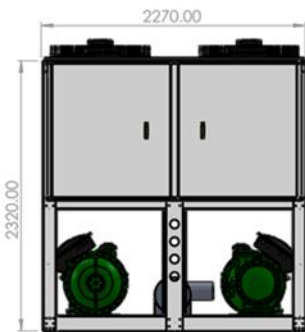
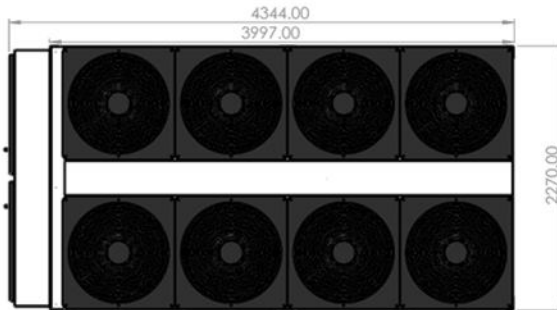
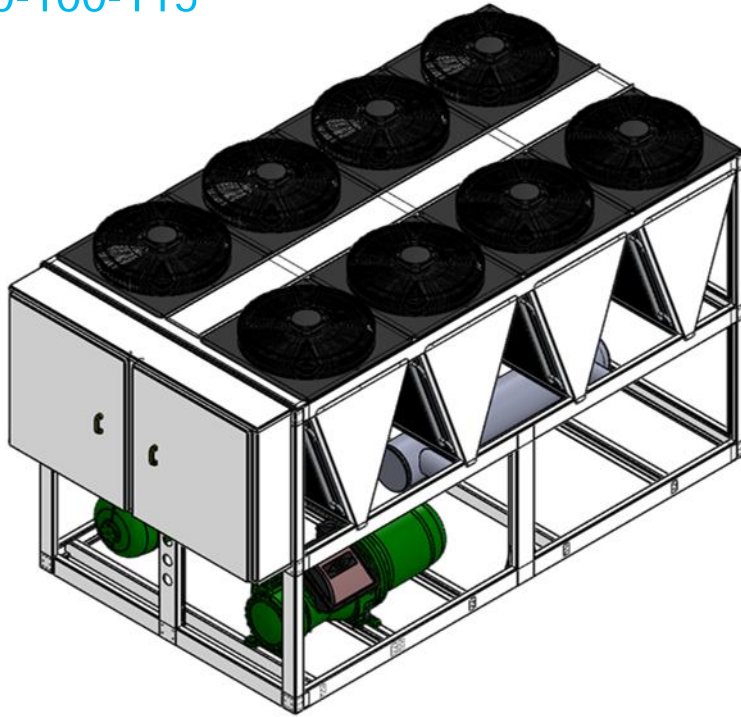

# UNIT DIMENSIONS

EACH 130-140-150

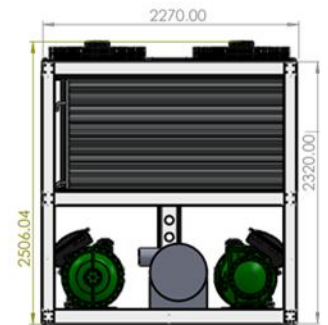
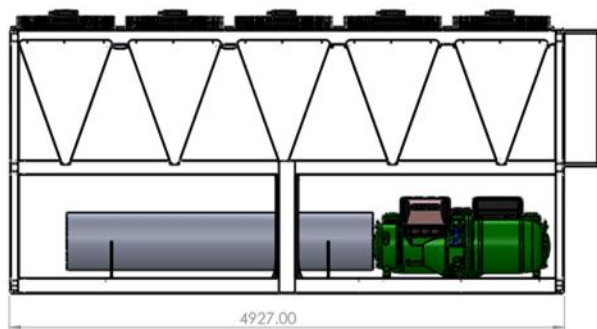
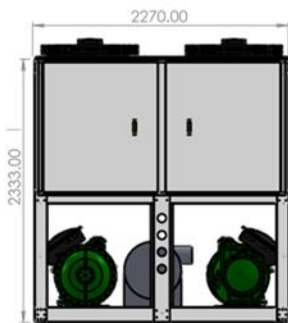
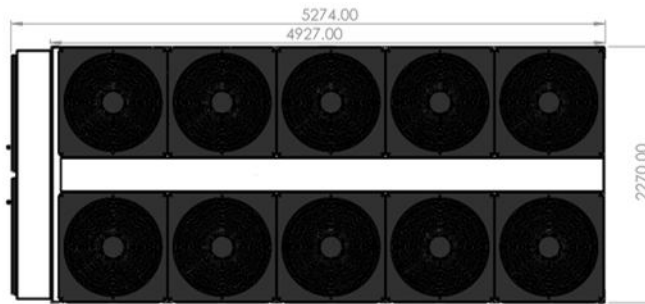
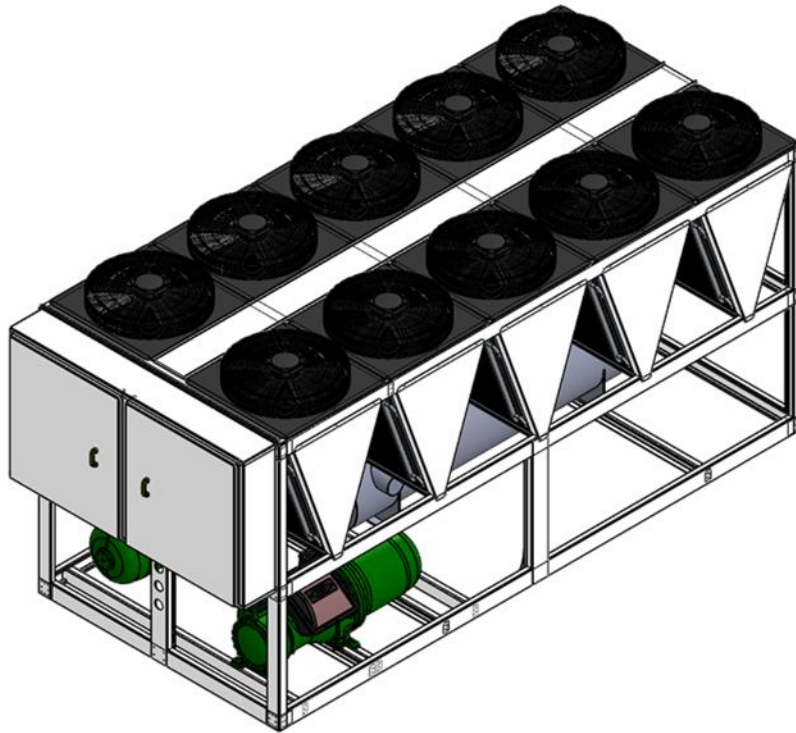

# UNIT DIMENSIONS

EACH 160-170

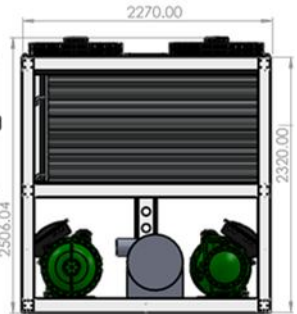
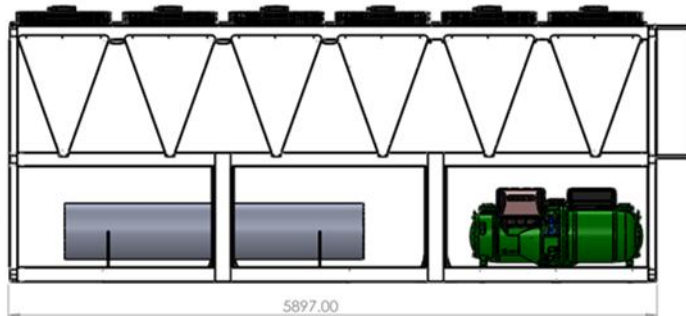
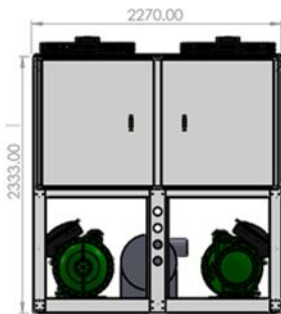
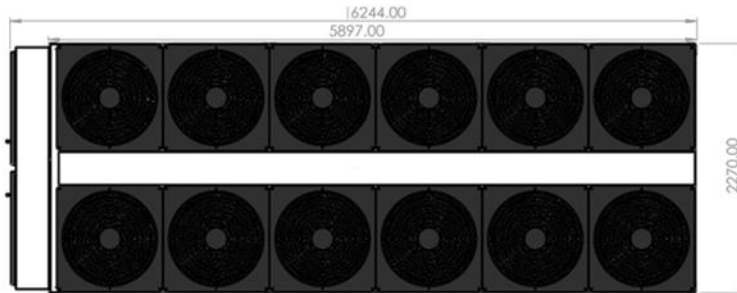
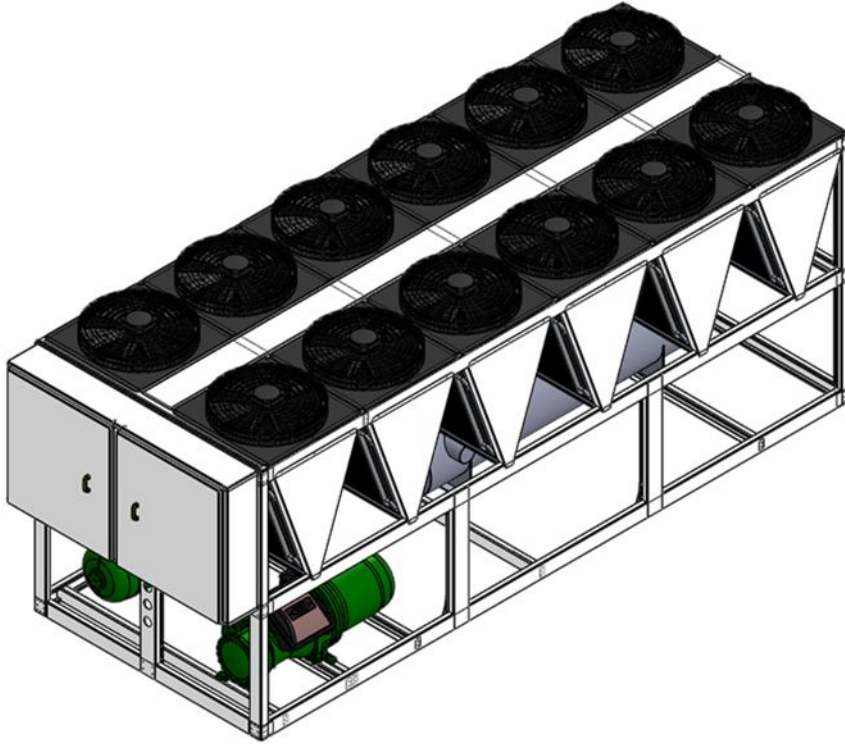

# UNIT DIMENSIONS

EACH 180-190-200

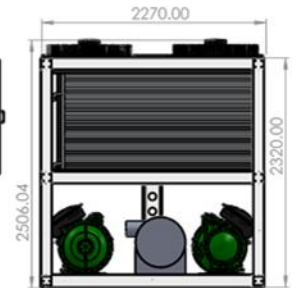
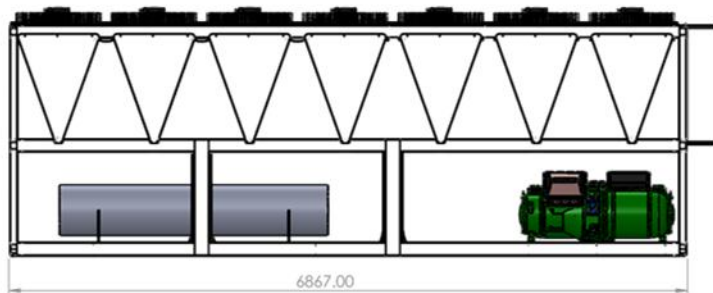
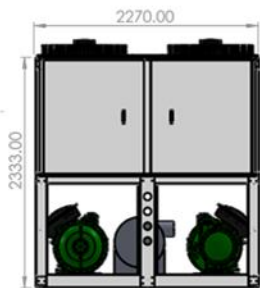
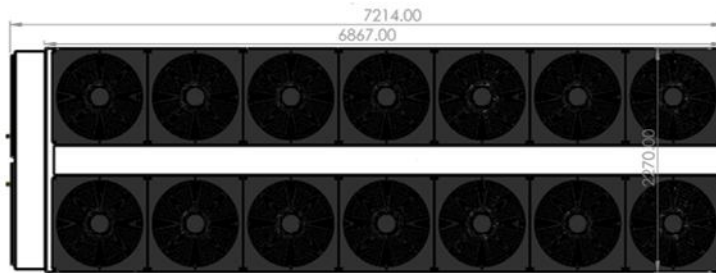
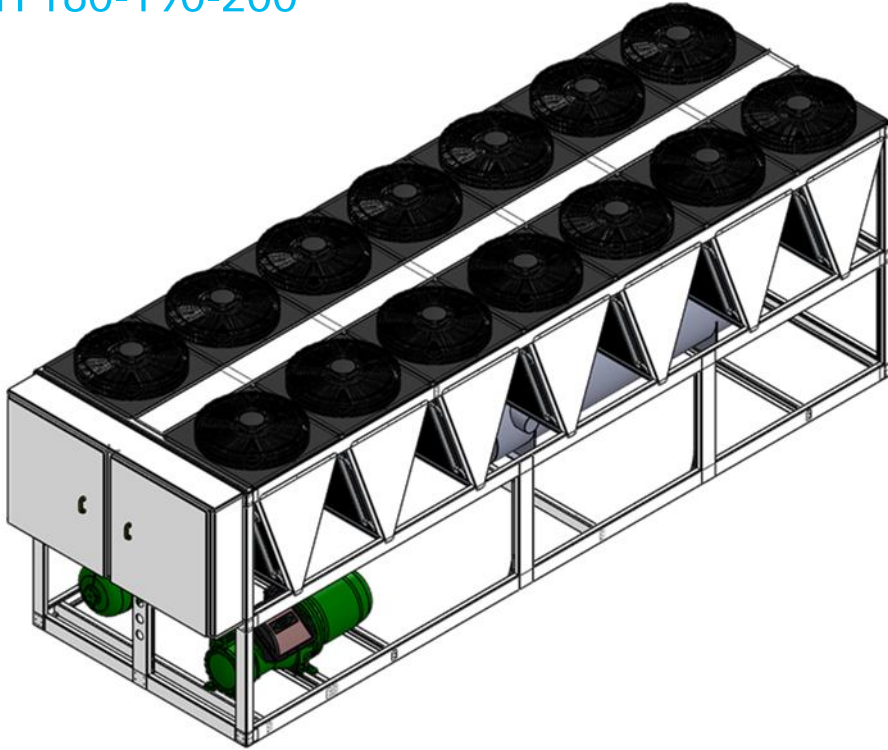



# UNIT DIMENSIONS

EACH 220-230-240

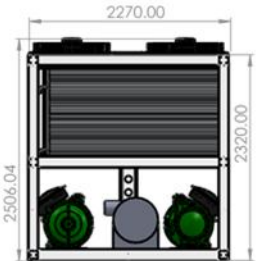
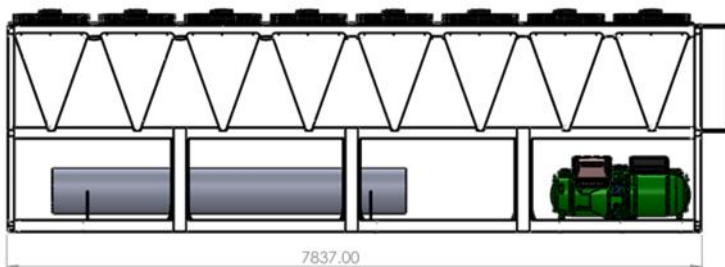
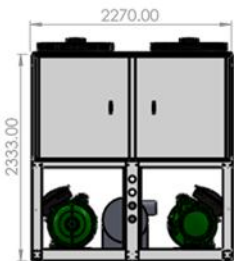
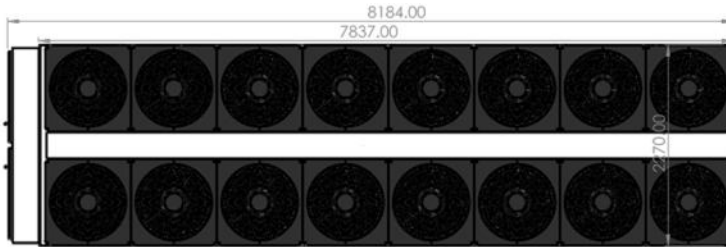
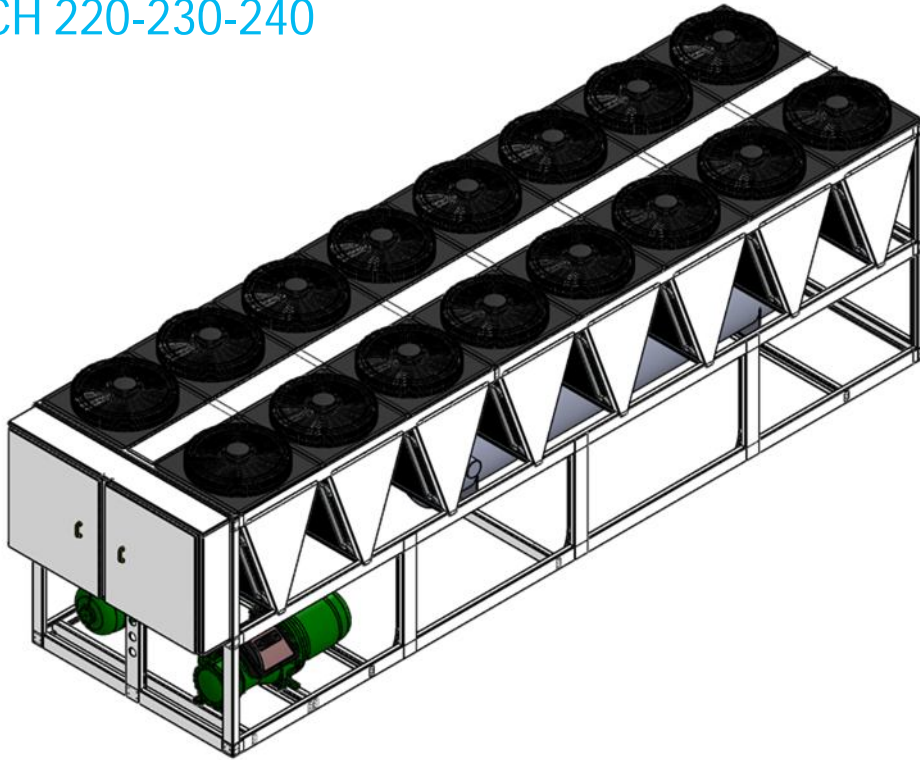

# UNIT DIMENSIONS

EACH 250-260-270-280

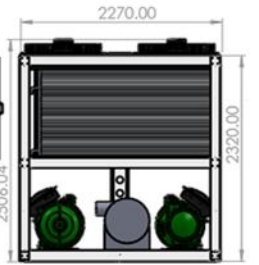
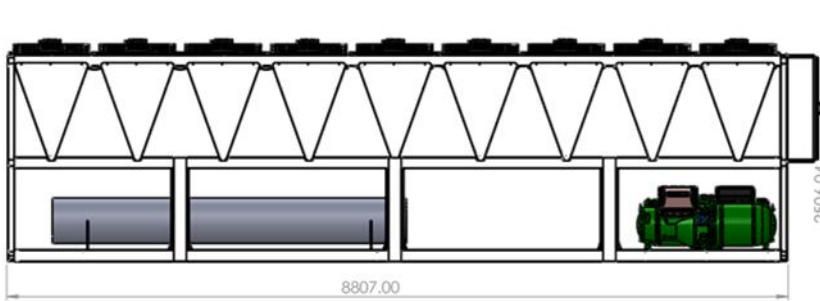
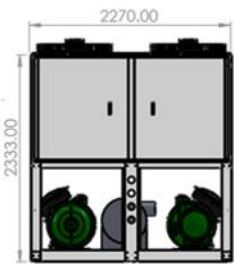
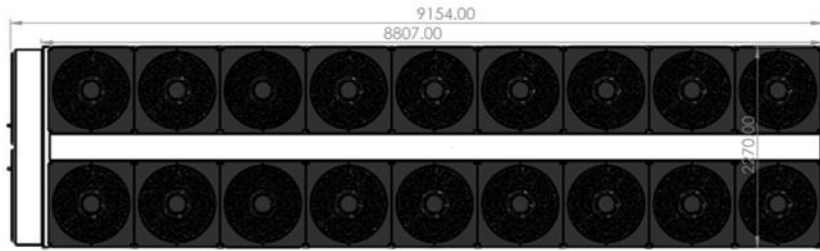
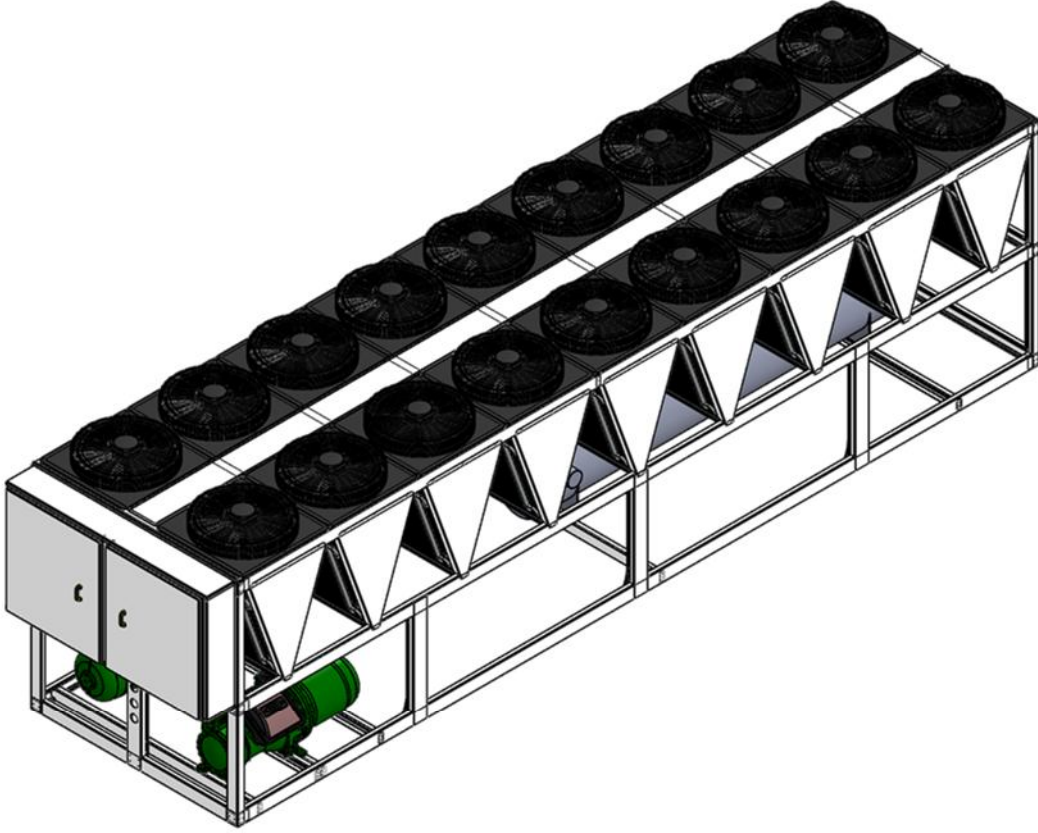

# UNIT DIMENSIONS

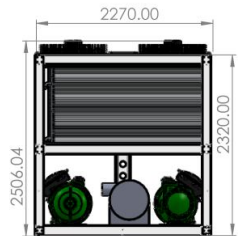
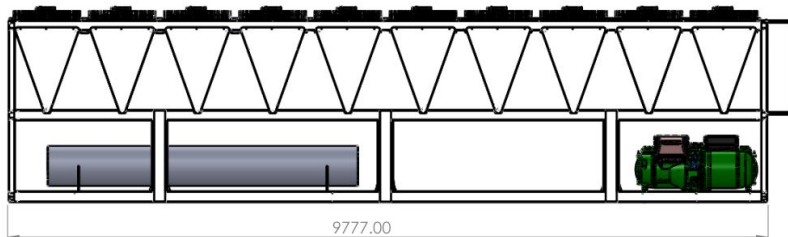
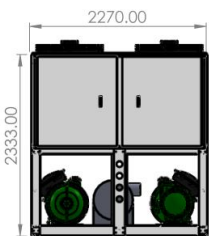
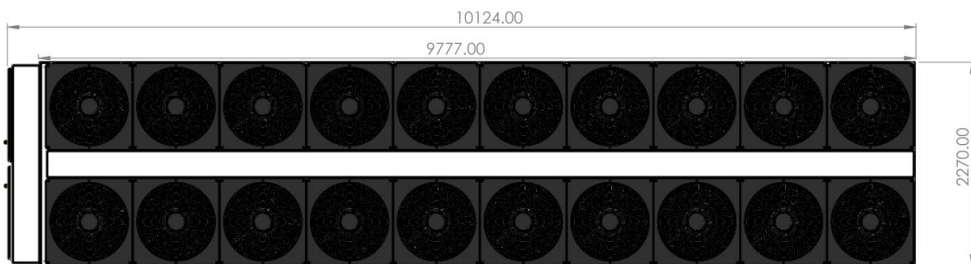
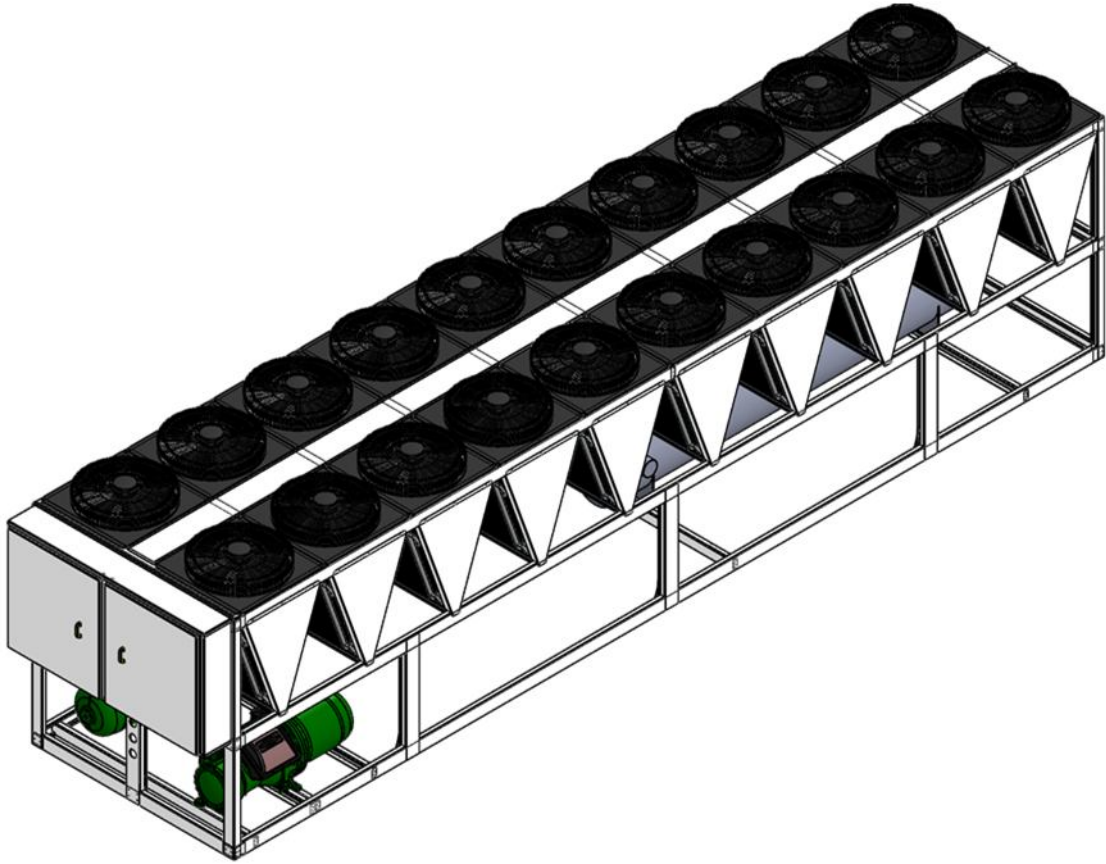

# UNIT DIMENSIONS

EACH 300-320

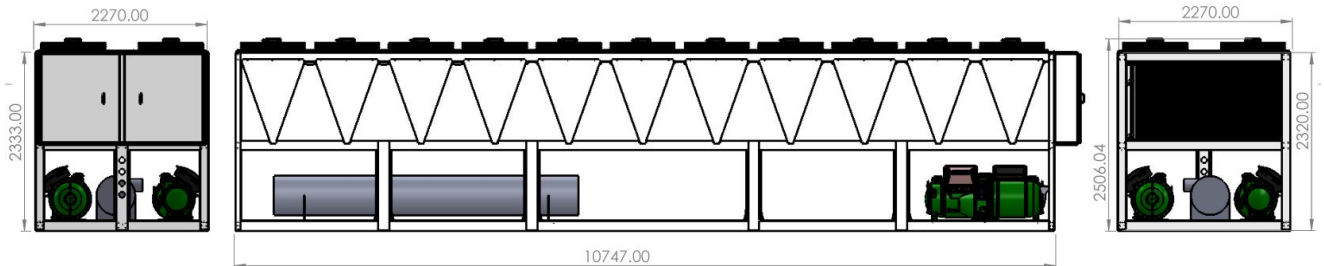
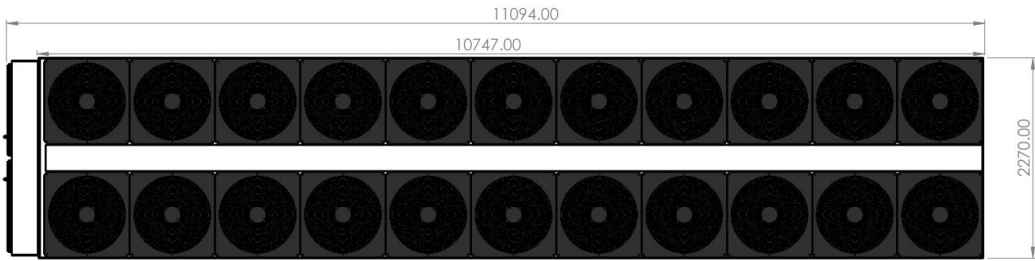
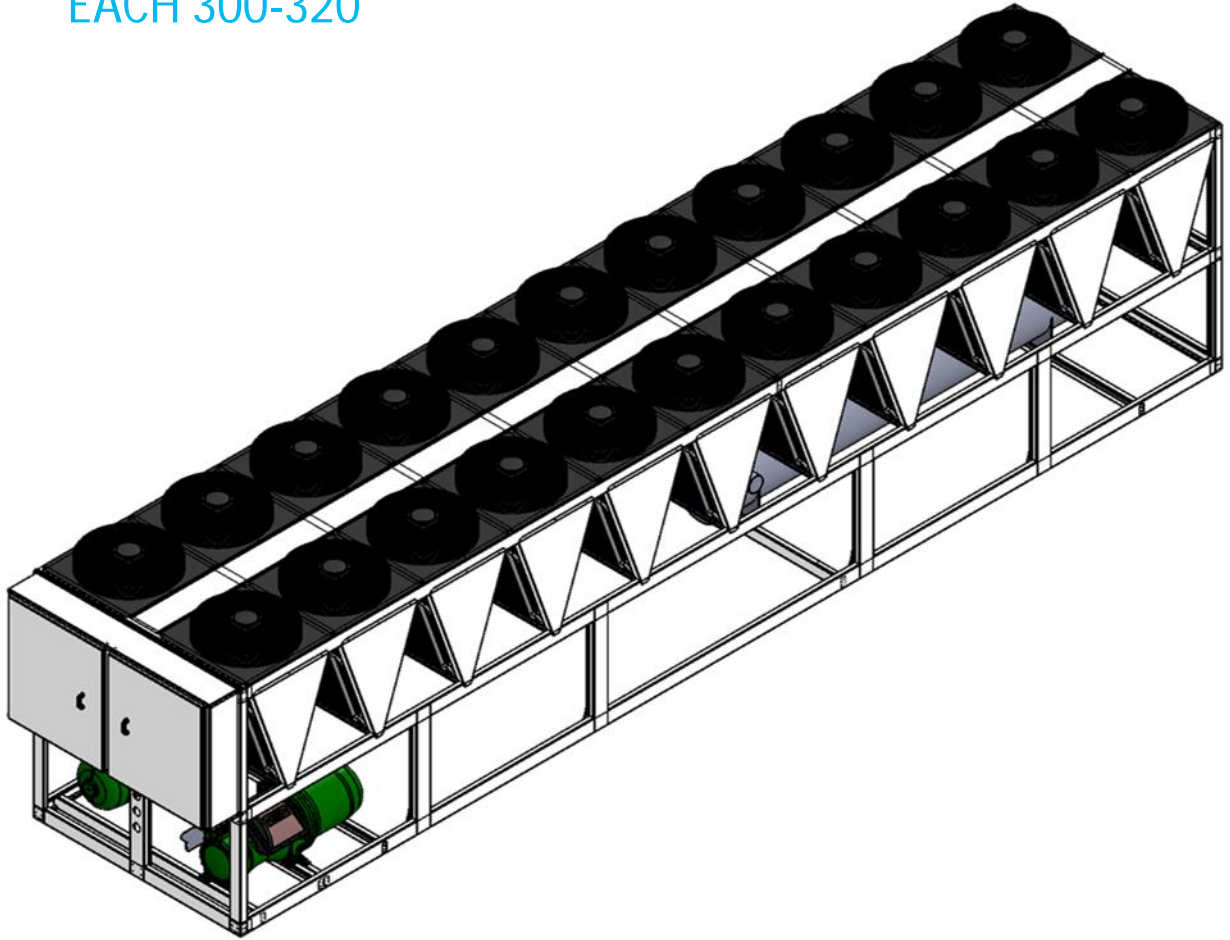



# UNIT DIMENSIONS

EACH 330-340-350

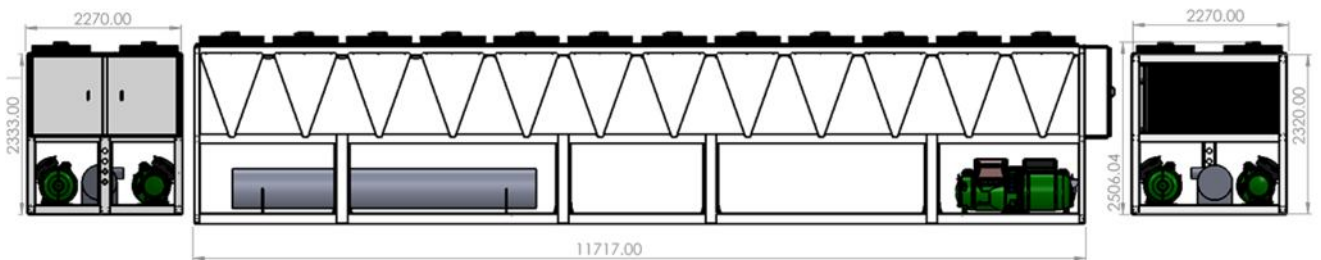
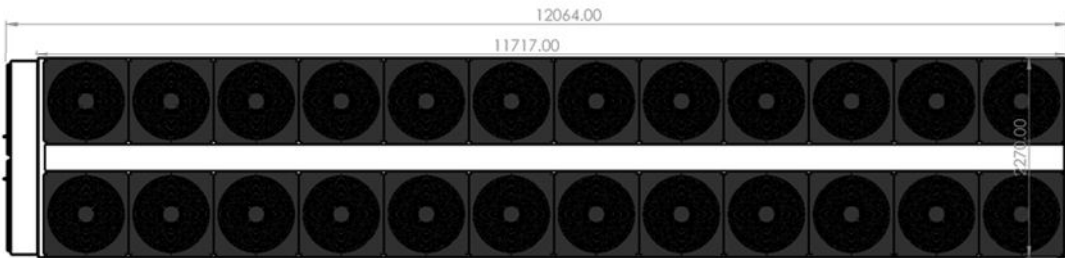
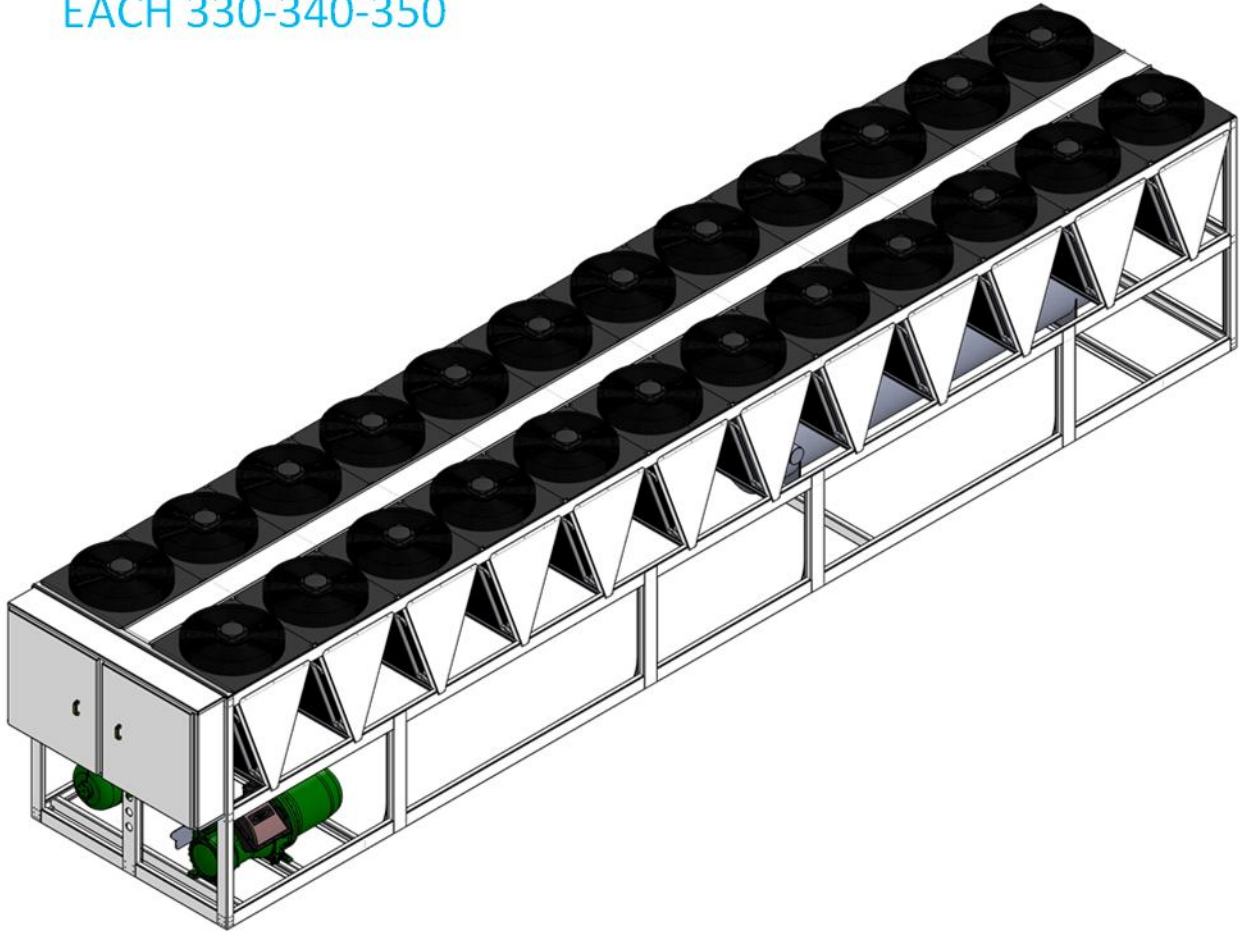

# Typical electrical wiring diagram

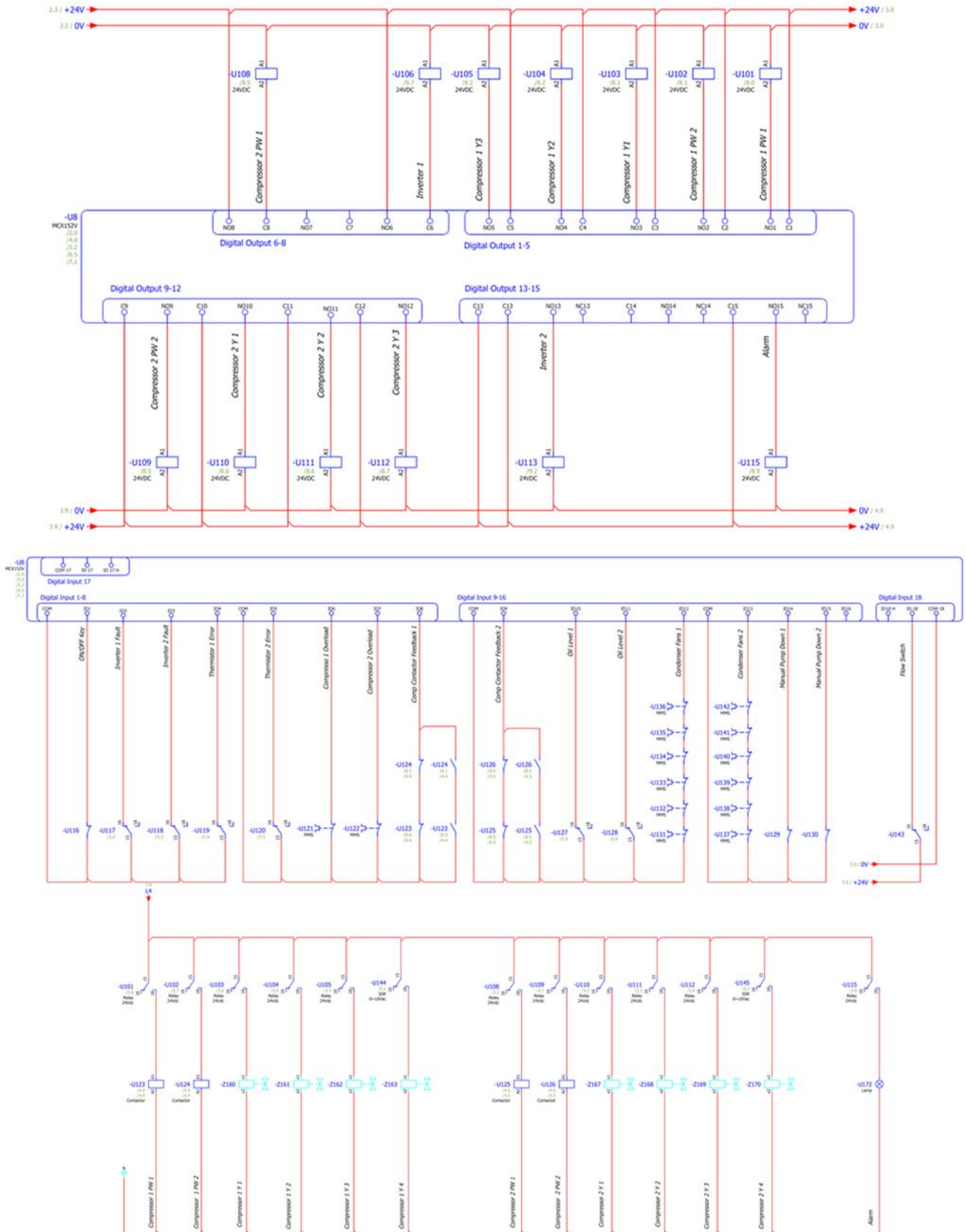

# TYPICAL WIRING DIAGRAM

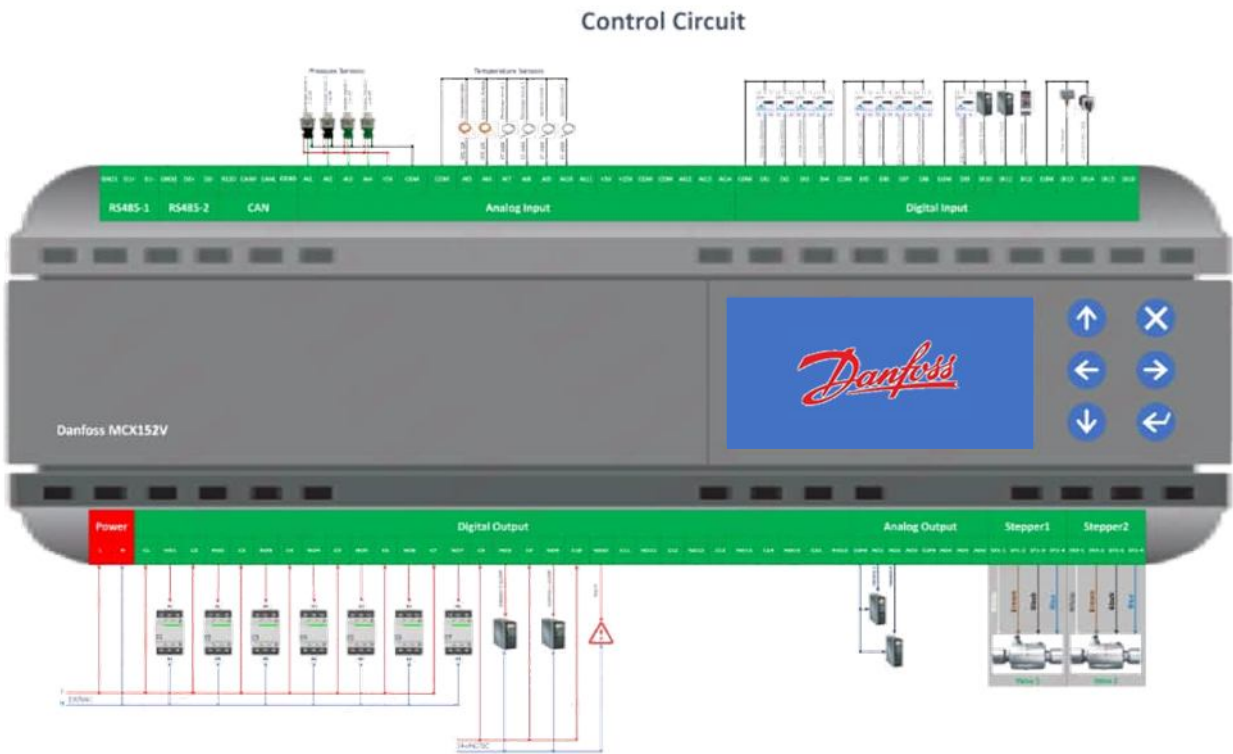

### Power Circuit

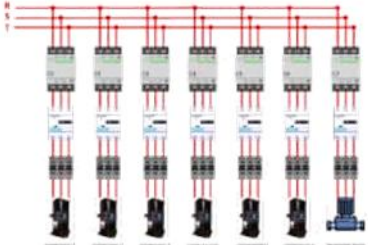





# . NOTE .

A large rectangular area with rounded corners, outlined in light blue, containing numerous horizontal light blue lines for writing. The lines are evenly spaced and cover the majority of the page below the header.





**ECO COOLER**  
AIR CONDITIONER