

R134A

# ECO COOLER

## ROOFTOP PACKAGE

50Hz

10% Fresh Air

2022

**ECO COOLER**  
AIR CONDITIONER

MULTI STAGE EVAPORATIVE COOLING







Special Public places  
Commercial, Office, Hospital, Restaurant,  
Coffee shop & Etc .



# ECO COOLER

AIR CONDITIONER



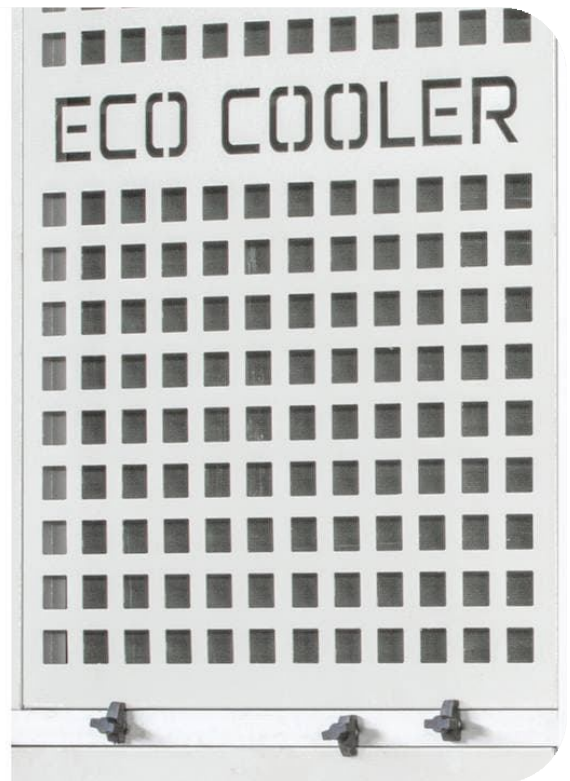

ECO COOLER

ECO COOTEK

## Table of Contents

INTRODUCTION	7
NOMENCLATURE	7
FEATURES AND BENEFITS	8
STANDARD SPECIFICATIONS	9
OPTIONAL FEATURES	15
TECHNICAL DATA	16
PERFORMANCE DATA TABLES	19
UNIT DIMENSIONS	24
Typical electrical wiring diagram	36
TYPICAL WIRING DIAGRAM	37

# INTRODUCTION

**ECO PACKAGE** High Efficiency Package Units are designed for outdoor installation specifically for tropical operation with high performance, low power consumption, easy installation and low noise operations.

**ECO PACKAGE** Packaged Units can be used for cooling or heating with optional electric heater.



# NOMENCLATURE

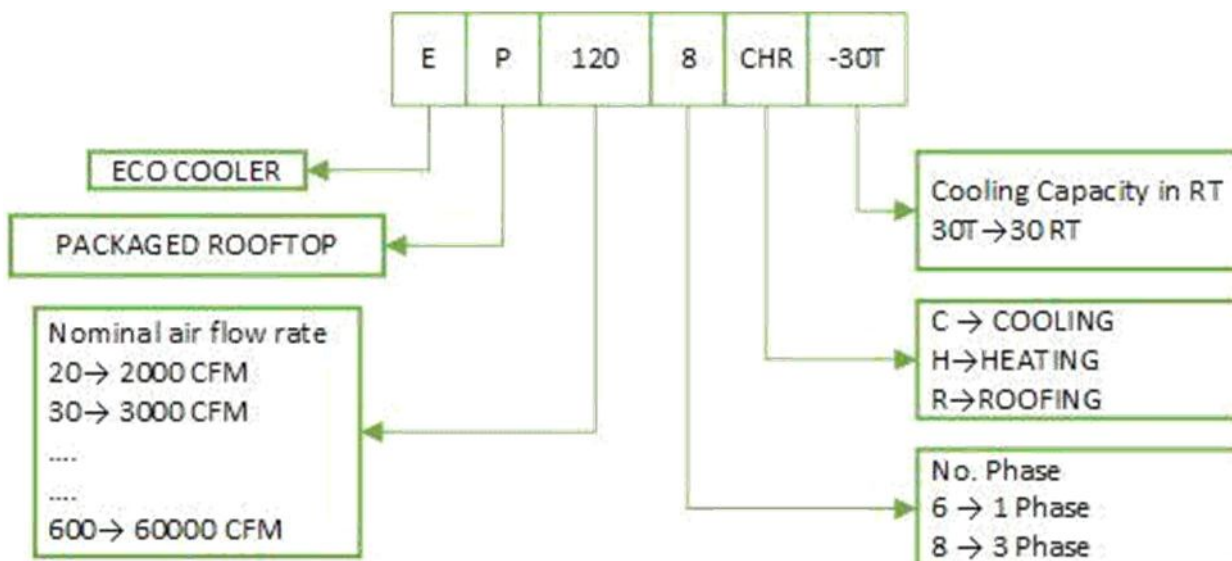



## OUTSTANDING FEATURES

### Applications

- 100% Fresh air applications
- Low cfm mixed air applications

### Superior Efficiency

- High EER (Energy Efficiency Ratio)
- Low power consumption
- Heavy duty, High volumetric efficiency scroll compressors
- High efficiency Back Inclined Evaporator Blowers
- Fans are manufactured in Galvanized Steel Sheet with Structurally reinforced housing
- Totally Enclosed Fan cooled (TEFC) Blower Motor, class F insulation, IP 55
- Designed to operate at severe ambient temperature up to 52°C without tripping
- Condenser and Evaporator Coils are heavy duty built up seamless copper tubes and mechanically bonded louvered hydrophilic fins
- Standard Refrigerant line accessories filter drier, sight glass, thermostatic expansion valves
- UL certified components
- Standard hot gas bypass
- Condenser coils metal guards

### Quiet operation

- Low noise level compressors, condenser fans, and evaporator blower
- Compact physical footprint
- Special designed refrigerant piping in addition to the insulation for the evaporator section

### controls

- Microprocessor Controller
- Single point power supply
- Color coded wires
- Weatherproof Control panel

### Quality Assurance

- All units in the FPNG series are :
  - Factory run tested
  - Produced in an ISO 9001-2000 listed manufacturing facility
  - Constructed in compliance with ASHRAE 15 safety requirements
  - AHRI certified cooling coils

### Options & Accessories

- Intelligent air Quality System by Economizer control
- Ultraviolet (UV) lamps
- Mild ambient control
- Return air Bag filters
- Electric Heaters
- Steam Humidifiers
- Anti ice thermostats



## OUTSTANDING FEATURES

### Evaporator's Side

- Easy access to the evaporator side with removable panel for maintenance purpose for the fan, motor, belt, pulleys and expansion valve
- Easy access for drain pan for cleaning

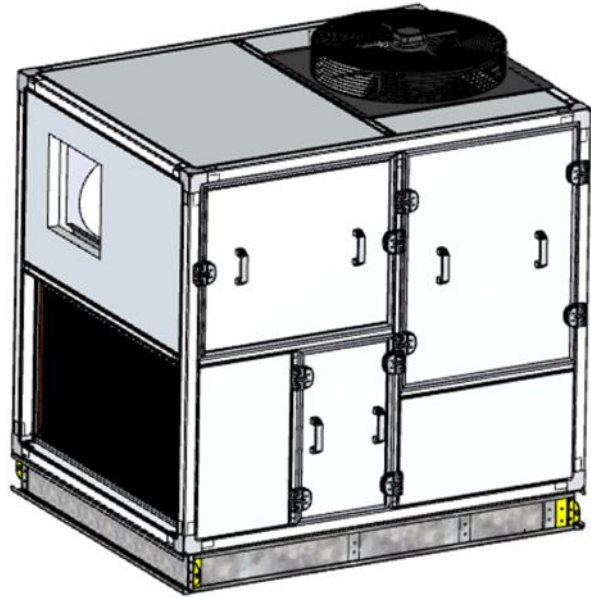

### Compressor's side

Easy access to the compressor side for maintenance purpose for the compressors and the filter drier  
 Easy access for the condenser fans and motors

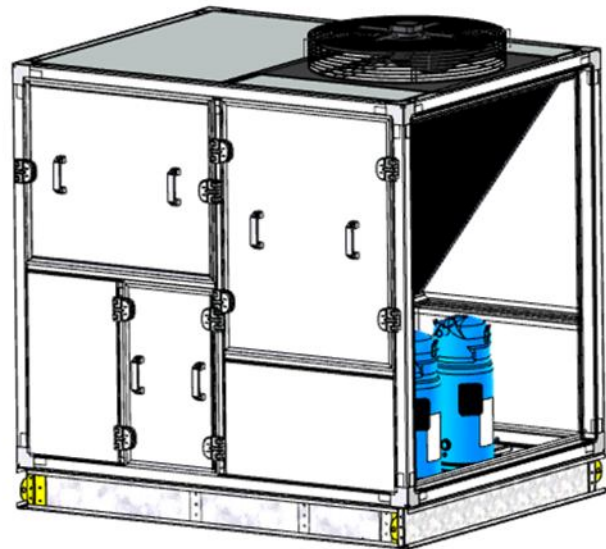

### Electrical Panel

- Easy access to the electrical panel with access panel for microprocessor access and electrical parts

## STANDARD SPECIFICATIONS

### General

The Fresh Air Package New Generation units (FPNG) are factory assembled cooling or combination of cooling and heating with electric heater, suitable for outdoor installation mounting on the roof or ground.

The Fresh Air packaged unit consists of scroll compressors, cooling coil, condenser coil, fans, electric heater (optional), control wiring and interconnecting piping-all factory assembled.

### Unit Casing

The casing sheet metal is fabricated from hot dipped G90, Zinc coating and zero spangle galvanized steel, oven-baked powder coated.

The unit is provided with an integral weather resistant control panel for outdoor application. Panels and access doors are provided for inspection and access for all internal parts.

### Evaporator Fan

The units are provided with centrifugal fans which are statically and dynamically balanced, designed for low sound level operation  
Belt driven.

### Evaporator Coils

The coils are built up of ripple finned seamless copper tubes and mechanically bonded to scientifically designed louvered fins.  
The assembled coils are factory leak tested under water at a pressure of 350 psig for quality and leak free units.

### Drain Pan

The drain pan is fabricated of galvanized steel.  
The drain pan is powder coat painted and the outer surface is thermally insulated.

### Compressor

The compressors are hermetic scroll type provided with crankcase heater, internal pressure relief valve which provides high pressure protection to the refrigerant system and rubber vibration isolators for quiet and efficient operation.  
The compressors are equipped with internal motor protector for safe operation. The compressors are built to NF, VPE, CSA, & UL certification.

### Condenser Coils

The coils are built up seamless copper tubes and mechanically bonded to scientifically designed louvered fins.  
The assembled coils are factory leak tested under water at a pressure of 450 psig for quality and leak free unit.

### Condenser Fans

The fans are selected for optimum efficiency and maximum sound power reduction, propeller type and direct driven, upward discharge and provided with fan grille mounted on the casing.

### Condenser Fan Motor

Condenser fan motors are totally enclosed air-over type with class F insulation. The motors are provided with inherent thermal protection and auto rest type.



## OPTIONAL SPECIFICATIONS

### Construction

- Double skin for evaporator side
- Coil protection materials: a) Polyurethane pre-coat Aluminum fins with copper tubes
- b) Tinned copper tubes with copper fins • Stainless steel drain pan
- Double side drain connections
- Other types of filter: synthetic fiber media for flat filter, 2" or 4" flat filter, bag filter" • Mixing box
- Vibration isolation for the unit :
- a) Neoprene rubber pads
- b) 1" spring isolator
- Lockable door for the control panel

### Electrical

- Electric heaters (open coil type)
- Electric heaters (fin type)
- Compressor circuit breaker
- Mild ambient (fan cycling) control
- Duct sensor
- Anti - ice thermostat
- Volt free contacts
- External overload
- Ultraviolet light
- Dirty filter indication
- Fire alarm connection
- Economizer controller
- Steam Humidifiers

### Refrigeration

- Pump down solenoid valve (PDS)
- Adjustable high-pressure switch
- Adjustable low-pressure switch
- Muffler
- Replaceable filter drier with mechanical shut-off valve



## MICROPROCESSOR CONTROLLER

### Microprocessor Based Controller

The Fresh Air Package New Generation units are provided with technologically advanced Microprocessor based controller, incorporating the following benefits and features:

- ANTI-RECYCLE TIMER
- Compressor lock out function
- Balance loading of compressors
- Compressor's lead-lag operation
- Pump down option.
- Fault diagnostics
- Indicator lights for high- & low-pressure Safeties





## SELECTION PROCEDURE

The below example illustrates the selection procedure to assist using this catalog to select the appropriate FPNG unit that meets the design requirements.

**Example :**

- Design requirements
- Total cooling capacity 201 [MBH]
  - Sensible cooling capacity 163 [MBH]
  - Design ambient temperature 115 [°F]
  - Evaporator air flow 3100 [CFM]
  - Evaporator entering temperature DB/WB 115/80 [°F/°F ]
  - External static pressure 1.0 [in. wg]
  - Altitude 2000 [ft]
  - Power supply 415V / 3Ph / 50Hz

Altitude [ft]	Correction factor
Sea level	1
1000	0.996
2000	0.990
3000	0.984
4000	0.980
5000	0.974
6000	0.965
7000	0.960

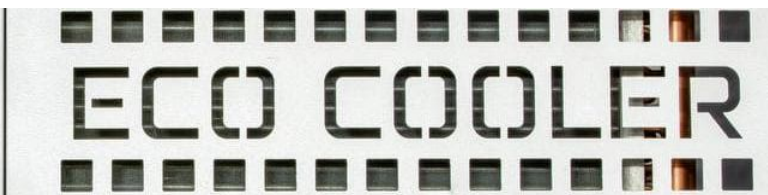

\*Using the correction factor table at the specified altitude, thereby the required capacity will be:

**Corrected capacity** = Required capacity / corr. factor

**Corrected total capacity** = 201[MBH]/0.99 = 203.03 MBH

**Corrected sensible capacity** = 163[MBH]/0.99 = 164.64 MBH

From the cooling capacity at performance data tables (page 10), the closest selection model to the required capacity is FPNG 240. From the performance table:

**Total capacity** = 206.63 [MBH]

**Sensible capacity** = 164.67 [MBH]

# GENERAL DATA

Model (HIGH EFFICIENT)		7T	10T	12T	15T	20T
Power supply [Volts/Phase/Hz]		415 V/3 Ph/ 50HZ				
Compressor	Type	Hermetic Scroll				
	Quantity	1	2	2	2	2
	Refrigeration Circuits	1	2	2	2	2
	Refrigerant	R134a				
	Expansion device type	Thermostatic Expansion Valves				
Condenser Fan	Type	Propeller-Direct Drive				
	Diameter, mm	630	800	800	800	900
	No. of fans	1	1	1	1	1
	Air Flow, m <sup>3</sup> /min. (CFM)	164.14(5800)	367.9(13000)	367.9(13000)	367.9(13000)	481.1(17000)
	Motor Enclosure/Ins. Class	Totally Enclosed Air Over, Class F / Class B				
	Nominal kW (HP)	0.53 (0.71)	0.53 (0.71)	2.1 (2.82)	2.1 (2.82)	2.05 (2.75)
	RPM	905	910	910	910	915
Condenser Section	Type	Microchannel				
	Rows/FPI	1/20				
	Total Face area, m <sup>2</sup>	1.0	2.0	2.0	2.0	3.0
	Total Face area, ft <sup>2</sup>	10.76	21.52	21.52	21.52	32.28
Supply motor and fan	Type	Forward - Belt Driven				
	No. of fans	1	1	1	1	1
	Motor Enclosure/Ins. Class	Totally Enclosed Fan Cooled (TEFC) , Class F Insulation				
	Nominal kW	0.28-1.1	0.66-2.5	0.66-2.5	0.66-2.5	0.66-2.5
Evaporator Coil	Type	Enhanced Fins and Tube				
	Rows/FPI	6/10				
	Total Face area, m <sup>2</sup>	0.52	0.82	0.82	0.82	1.1
	Total Face area, ft <sup>2</sup>	5.6	8.8	8.8	8.8	11.8
Air Filter	Type	Washable Aluminum mesh				
	Thickness [inch]	2"				
Operating Weight	kg					

Model (HIGH EFFICIENT)		25T	30T	35T	40T	45T
Power supply [Volts/Phase/Hz]		415 V/3 Ph/ 50HZ				
Compressor	Type	Hermetic Scroll				
	Quantity	4	4	4	6	6
	Refrigeration Circuits	2	2	2	2	2
	Refrigerant	R134a				
	Expansion device type	Thermostatic Expansion Valves				
Condenser Fan	Type	Propeller-Direct Drive				
	Diameter, mm	800	800	800	800	800
	No. of fans	2	2	3	3	3
	Air Flow, m <sup>3</sup> /min. (CFM)	735.8(26000)	735.8(26000)	1103.7(39000)	1103.7(39000)	1103.7(39000)
	Motor Enclosure/Ins. Class	Totally Enclosed Air Over, Class F / Class B				
	Nominal kW (HP)	2 * 2.1 (2.82)	2 * 2.1 (2.82)	3 * 2.1 (2.82)	3 * 2.1 (2.82)	3 * 2.1 (2.82)
	RPM	910	910	910	910	910
Condenser Section	Type	Microchannel				
	Rows/FPI	1/20				
	Total Face area, m <sup>2</sup>	4.0	4.0	6.0	6.0	6.0
	Total Face area, ft <sup>2</sup>	43.04	43.04	64.56	64.56	64.56
Supply motor and fan	Type	Forward - Belt Driven				
	No. of fans	2	2	2	2	2
	Motor Enclosure/Ins. Class	Totally Enclosed Fan Cooled (TEFC) , Class F Insulation				
	Nominal kW	1.8-7	1.8-7	2.2-8.8	2.2-8.8	2.2-8.8
Evaporator Coil	Type	Enhanced Fins and Tube				
	Rows/FPI	6/10				
	Total Face area, m <sup>2</sup>	2.24	2.24	3.6	3.6	3.6
	Total Face area, ft <sup>2</sup>	24.1	24.1	38.7	38.7	38.7
Air Filter	Type	Washable Aluminum mesh				
	Thickness [inch]	2"				
Operating Weight	kg					

# GENERAL DATA

Model (HIGH EFFICIENT)		50T	55T	60T	65T	70T
Power supply [Volts/Phase/Hz]		415 V/3 Ph/ 50 HZ				
Compressor	Type	Hermetic Scroll				
	Quantity	6	8	8	8	8
	Refrigeration Circuits	2	4	4	4	4
	Refrigerant	R134a				
Expansion device type		Thermostatic Expansion Valves				
Condenser Fan	Type	Propeller-Direct Drive				
	Diameter, mm	800	800	800	800	800
	No. of fans	3	4	4	4	4
	Air Flow, m <sup>3</sup> /min. (CFM)	1103.7(39000)	1471.6(52000)	1471.6(52000)	1471.6(52000)	1471.6(52000)
	Motor Enclosure/Ins .Class	Totally Enclosed Air Over, Class F / Class B				
	Nominal kW (HP)	3 * 2.1 (2.82)	4 * 2.1 (2.82)	4 * 2.1 (2.82)	4 * 2.1 (2.82)	4 * 2.1 (2.82)
	RPM	910	910	910	910	910
Condenser Section	Type	Microchannel				
	Rows/FPI	1/20				
	Total Face area, m <sup>2</sup>	6.0	8.0	8.0	8.0	8.0
	Total Face area, ft <sup>2</sup>	64.56	86.08	86.08	86.08	86.08
Supply motor and fan	Type	Forward - Belt Driven				
	No. of fans	2	4	4	4	4
	Motor Enclosure/Ins .Class	Totally Enclosed Fan Cooled (TEFC) , Class F Insulation				
	Nominal kW	2.2-8.8	3.6-14	3.6-14	3.6-14	3.6-14
Evaporator Coil	Type	Enhanced Fins and Tube				
	Rows/FPI	6/10				
	Total Face area, m <sup>2</sup>	3.6	4.48	4.48	4.48	4.48
	Total Face area, ft <sup>2</sup>	38.7	48.2	48.2	48.2	48.2
Air Filter	Type	Washable Aluminum mesh				
	Thickness [inch]	2"				
Operating Weight	kg					

Model (HIGH EFFICIENT)		80T	90T	100T	110T	120T
Power supply [Volts/Phase/Hz]		415 V/3 Ph/ 50 HZ				
Compressor	Type	Hermetic Scroll				
	Quantity	12	12	12	12	12
	Refrigeration Circuits	4	4	4	4	4
	Refrigerant	R134a				
Expansion device type		Thermostatic Expansion Valves				
Condenser Fan	Type	Propeller-Direct Drive				
	Diameter, mm	800	800	800	800	800
	No. of fans	6	6	6	6	6
	Air Flow, m <sup>3</sup> /min. (CFM)	2207.4(78000)	2207.4(78000)	2207.4(78000)	2207.4(78000)	2207.4(78000)
	Motor Enclosure/Ins .Class	Totally Enclosed Air Over, Class F / Class B				
	Nominal kW (HP)	6 * 2.1 (2.82)	6 * 2.1 (2.82)	6 * 2.1 (2.82)	6 * 2.1 (2.82)	6 * 2.1 (2.82)
	RPM	910	910	910	910	910
Condenser Section	Type	Microchannel				
	Rows/FPI	1/20				
	Total Face area, m <sup>2</sup>	12.0	12.0	12.0	12.0	12.0
	Total Face area, ft <sup>2</sup>	129.12	129.12	129.12	129.12	129.12
Supply motor and fan	Type	Forward - Belt Driven				
	No. of fans	4	4	4	4	4
	Motor Enclosure/Ins .Class	Totally Enclosed Fan Cooled (TEFC) , Class F Insulation				
	Nominal kW	4.4-17.6	4.4-17.6	4.4-17.6	4.4-17.6	4.4-17.6
Evaporator Coil	Type	Enhanced Fins and Tube				
	Rows/FPI	6/10				
	Total Face area, m <sup>2</sup>	7.2	7.2	7.2	7.2	7.2
	Total Face area, ft <sup>2</sup>	77.4	77.4	77.4	77.4	77.4
Air Filter	Type	Washable Aluminum mesh				
	Thickness [inch]	2"				
Operating Weight	kg					



# GENERAL DATA

Model (STANDARD)		7T	10T	12T	15T	20T
Power supply [Volts/Phase/Hz]		415 V/3 Ph/ 50HZ				
Compressor	Type	Hermetic Scroll				
	Quantity	1	2	2	2	4
	Refrigeration Circuits	1	1	1	2	2
	Refrigerant	R134a				
Expansion device type		Thermostatic Expansion Valves				
Condenser Fan	Type	Propeller-Direct Drive				
	Diameter, mm	630	630	630	800	800
	No. of fans	1	1	1	1	1
	Air Flow, m <sup>3</sup> /min. (CFM)	164.14(5800)	164.14(5800)	164.14(5800)	367.9(13000)	367.9(13000)
	Motor Enclosure/Ins .Class	Totally Enclosed Air Over, Class F / Class B				
	Nominal kW (HP)	0.53 (0.71)	0.53 (0.71)	0.53 (0.71)	2.1 (2.82)	2.1 (2.82)
RPM	905	905	905	910	910	
Condenser Section	Type	Microchannel				
	Rows/FPI	1/20				
	Total Face area, m <sup>2</sup>	1.0	1.0	1.0	2.0	2.0
	Total Face area, ft <sup>2</sup>	10.76	10.76	10.76	21.52	21.52
Supply motor and fan	Type	Forward - Belt Driven				
	No. of fans	1	1	1	1	1
	Motor Enclosure/Ins .Class	Totally Enclosed Fan Cooled (TEFC) , Class F Insulation				
	Nominal kW	0.28-1.1	0.28-1.1	0.28-1.1	0.66-2.5	0.66-2.5
Evaporator Coil	Type	Enhanced Fins and Tube				
	Rows/FPI	6/10				
	Total Face area, m <sup>2</sup>	0.52	0.52	0.52	0.82	0.82
	Total Face area, ft <sup>2</sup>	5.6	5.6	5.6	8.8	8.8
Air Filter	Type	Washable Aluminum mesh				
	Thickness [inch]	2"				
Operating Weight	kg					

Model (STANDARD)		25T	30T	35T	40T	45T
Power supply [Volts/Phase/Hz]		415 V/3 Ph/ 50HZ				
Compressor	Type	Hermetic Scroll				
	Quantity	4	4	4	6	6
	Refrigeration Circuits	2	2	2	2	2
	Refrigerant	R134a				
Expansion device type		Thermostatic Expansion Valves				
Condenser Fan	Type	Propeller-Direct Drive				
	Diameter, mm	800	900	900	800	800
	No. of fans	1	1	1	2	2
	Air Flow, m <sup>3</sup> /min. (CFM)	367.9(13000)	481.1(17000)	481.1(17000)	735.8(26000)	735.8(26000)
	Motor Enclosure/Ins .Class	Totally Enclosed Air Over, Class F / Class B				
	Nominal kW (HP)	2.1 (2.82)	2.05 (2.75)	2.05 (2.75)	2 * 2.1 (2.82)	2 * 2.1 (2.82)
RPM	910	915	915	910	910	
Condenser Section	Type	Microchannel				
	Rows/FPI	1/20				
	Total Face area, m <sup>2</sup>	2.0	3.0	3.0	4.0	4.0
	Total Face area, ft <sup>2</sup>	21.52	32.28	32.28	43.04	43.04
Supply motor and fan	Type	Forward - Belt Driven				
	No. of fans	1	1	1	2	2
	Motor Enclosure/Ins .Class	Totally Enclosed Fan Cooled (TEFC) , Class F Insulation				
	Nominal kW	0.66-2.5	0.66-2.5	0.66-2.5	1.8-7	1.8-7
Evaporator Coil	Type	Enhanced Fins and Tube				
	Rows/FPI	6/10				
	Total Face area, m <sup>2</sup>	0.82	1.1	1.1	2.24	2.24
	Total Face area, ft <sup>2</sup>	8.8	11.8	11.8	24.1	24.1
Air Filter	Type	Washable Aluminum mesh				
	Thickness [inch]	2"				
Operating Weight	kg					

# GENERAL DATA

Model (STANDARD)		50T	55T	60T	65T	70T
Power supply [Volts/Phase/Hz]		415 V/3 Ph/ 50HZ				
Compressor	Type	Hermetic Scroll				
	Quantity	6	8	8	8	10
	Refrigeration Circuits	2	2	2	2	2
	Refrigerant	R134a				
Expansion device type		Thermostatic Expansion Valves				
Condenser Fan	Type	Propeller-Direct Drive				
	Diameter, mm	800	800	800	800	800
	No. of fans	2	3	3	3	3
	Air Flow, m <sup>3</sup> /min. (CFM)	735.8(26000)	1103.7(39000)	1103.7(39000)	1103.7(39000)	1103.7(39000)
	Motor Enclosure/Ins. Class	Totally Enclosed Air Over, Class F / Class B				
	Nominal kW (HP)	2 * 2.1 (2.82)	3 * 2.1 (2.82)	3 * 2.1 (2.82)	3 * 2.1 (2.82)	3 * 2.1 (2.82)
RPM	910	910	910	910	910	
Condenser Section	Type	Microchannel				
	Rows/FPI	1/20				
	Total Face area, m <sup>2</sup>	4.0	6.0	6.0	6.0	6.0
	Total Face area, ft <sup>2</sup>	43.04	64.56	64.56	64.56	64.56
Supply motor and fan	Type	Forward - Belt Driven				
	No. of fans	2	2	2	2	2
	Motor Enclosure/Ins. Class	Totally Enclosed Fan Cooled (TEFC) , Class F Insulation				
	Nominal kW	1.8-7	2.2-8.8	2.2-8.8	2.2-8.8	2.2-8.8
Evaporator Coil	Type	Enhanced Fins and Tube				
	Rows/FPI	6/10				
	Total Face area, m <sup>2</sup>	2.24	3.6	3.6	3.6	3.6
	Total Face area, ft <sup>2</sup>	24.1	38.7	38.7	38.7	38.7
Air Filter	Type	Washable Aluminum mesh				
	Thickness [inch]	2"				
Operating Weight	kg					

Model (STANDARD)		80T	90T	100T	110T	120T
Power supply [Volts/Phase/Hz]		415 V/3 Ph/ 50HZ				
Compressor	Type	Hermetic Scroll				
	Quantity	12	12	12	16	16
	Refrigeration Circuits	4	4	4	4	4
	Refrigerant	R134a				
Expansion device type		Thermostatic Expansion Valves				
Condenser Fan	Type	Propeller-Direct Drive				
	Diameter, mm	800	800	800	800	800
	No. of fans	4	4	4	4	6
	Air Flow, m <sup>3</sup> /min. (CFM)	1471.6(52000)	1471.6(52000)	1471.6(52000)	1471.6(52000)	2207.4(78000)
	Motor Enclosure/Ins. Class	Totally Enclosed Air Over, Class F / Class B				
	Nominal kW (HP)	4 * 2.1 (2.82)	4 * 2.1 (2.82)	4 * 2.1 (2.82)	4 * 2.1 (2.82)	6 * 2.1 (2.82)
RPM	910	910	910	910	910	
Condenser Section	Type	Microchannel				
	Rows/FPI	1/20				
	Total Face area, m <sup>2</sup>	8.0	8.0	8.0	8.0	12.0
	Total Face area, ft <sup>2</sup>	86.08	86.08	86.08	86.08	129.12
Supply motor and fan	Type	Forward - Belt Driven				
	No. of fans	4	4	4	4	4
	Motor Enclosure/Ins. Class	Totally Enclosed Fan Cooled (TEFC) , Class F Insulation				
	Nominal kW	3.6-14	3.6-14	3.6-14	3.6-14	4.4-17.6
Evaporator Coil	Type	Enhanced Fins and Tube				
	Rows/FPI	6/10				
	Total Face area, m <sup>2</sup>	4.48	4.48	4.48	4.48	7.2
	Total Face area, ft <sup>2</sup>	48.2	48.2	48.2	48.2	77.4
Air Filter	Type	Washable Aluminum mesh				
	Thickness [inch]	2"				
Operating Weight	kg					

# PERFORMANCE DATA TABLES

Model (HIGH EFFICIENT)	Air Flow Rate (CFM)	RH%	Condenser Ambient Temperature [F]									
			85		95		105		115		125	
			Capacity (MBH)		Capacity (MBH)		Capacity (MBH)		Capacity (MBH)		Capacity (MBH)	
			Total	Sen.	Total	Sen.	Total	Sen.	Total	Sen.	Total	Sen.
7T	1400	50	44.2	34.1	47.5	35	50.9	35.6	55.7	36.5	61.2	37.1
	3080	50	66.9	58.6	72.7	60.3	78.9	61.4	85.6	62	93.4	62.2
10T	2193	50	69.7	53.6	74.9	55.1	81.2	56.5	88.1	57.5	96.6	58.5
	4824	50	107.6	93	115.3	95.1	124.7	96.7	135.4	97.8	147.5	98
12T	2193	50	69.7	53.6	74.9	55.1	81.2	56.5	88.1	57.5	96.6	58.5
	4824	50	107.6	93	115.3	95.1	124.7	96.7	135.4	97.8	147.5	98
15T	2193	50	69.7	53.6	74.9	55.1	81.2	56.5	88.1	57.5	96.6	58.5
	4824	50	107.6	93	115.3	95.1	124.7	96.7	135.4	97.8	147.5	98
20T	2957	50	93.8	72.1	100.9	74.3	109.6	76.2	118.6	77.5	130	78.7
	6505	50	145	125.3	155	128	167.8	130.3	182.1	131.7	198.4	131.9
25T	6023	50	192.2	147.4	207	151.9	222.2	154.8	241.9	158	264.6	160.3
	13250	50	292.6	254.1	317.6	261.4	344.7	266.5	374.1	269.5	406.4	269.5
30T	6023	50	192.2	147.4	207	151.9	222.2	154.8	241.9	158	264.6	160.3
	13250	50	292.6	254.1	317.6	261.4	344.7	266.5	374.1	269.5	406.4	269.5
35T	9673	50	309.9	237.3	332	243.7	355.9	248.2	380.6	250.5	418.4	254.7
	21281	50	467	406.9	489.2	411.5	542.8	423.7	598.1	431.7	658.9	435.3
40T	9673	50	309.9	237.3	332	243.7	355.9	248.2	380.6	250.5	418.4	254.7
	21281	50	467	406.9	489.2	411.5	542.8	423.7	598.1	431.7	658.9	435.3
45T	9673	50	309.9	237.3	332	243.7	355.9	248.2	380.6	250.5	418.4	254.7
	21281	50	467	406.9	489.2	411.5	542.8	423.7	598.1	431.7	658.9	435.3



# PERFORMANCE DATA TABLES

Model (HIGH EFFICIENT)	Air Flow Rate (CFM)	RH%	Condenser Ambient Temperature [F]									
			85		95		105		115		125	
			Capacity (MBH)		Capacity (MBH)		Capacity (MBH)		Capacity (MBH)		Capacity (MBH)	
			Total	Sen.	Total	Sen.	Total	Sen.	Total	Sen.	Total	Sen.
50T	9673	50	309.9	237.3	332	243.7	355.9	248.2	380.6	250.5	418.4	254.7
	21281	50	467	406.9	489.2	411.5	542.8	423.7	598.1	431.7	658.9	435.3
55T	12046	50	384.4	294.8	414	303.8	444.4	309.6	483.8	316	529.2	320.6
	26500	50	585.2	508.2	635.2	522.8	689.4	533	748.2	539	812.8	539
60T	12046	50	384.4	294.8	414	303.8	444.4	309.6	483.8	316	529.2	320.6
	26500	50	585.2	508.2	635.2	522.8	689.4	533	748.2	539	812.8	539
65T	12046	50	384.4	294.8	414	303.8	444.4	309.6	483.8	316	529.2	320.6
	26500	50	585.2	508.2	635.2	522.8	689.4	533	748.2	539	812.8	539
70T	19346	50	619.8	474.6	664	487.4	711.8	496.4	761.2	501	836.8	509.4
	42562	50	934	813.8	978.4	823	1085.6	847.4	1196.2	863.4	1317.8	870.6
80T	19346	50	619.8	474.6	664	487.4	711.8	496.4	761.2	501	836.8	509.4
	42562	50	934	813.8	978.4	823	1085.6	847.4	1196.2	863.4	1317.8	870.6
90T	19346	50	619.8	474.6	664	487.4	711.8	496.4	761.2	501	836.8	509.4
	42562	50	934	813.8	978.4	823	1085.6	847.4	1196.2	863.4	1317.8	870.6
100T	19346	50	619.8	474.6	664	487.4	711.8	496.4	761.2	501	836.8	509.4
	42562	50	934	813.8	978.4	823	1085.6	847.4	1196.2	863.4	1317.8	870.6
110T	19346	50	619.8	474.6	664	487.4	711.8	496.4	761.2	501	836.8	509.4
	42562	50	934	813.8	978.4	823	1085.6	847.4	1196.2	863.4	1317.8	870.6
120T	19346	50	619.8	474.6	664	487.4	711.8	496.4	761.2	501	836.8	509.4
	42562	50	934	813.8	978.4	823	1085.6	847.4	1196.2	863.4	1317.8	870.6

# PERFORMANCE DATA TABLES

Model (STANDARD)	Air Flow Rate (CFM)	RH%	Condenser Ambient Temperature [F]									
			85		95		105		115		125	
			Capacity (MBH)		Capacity (MBH)		Capacity (MBH)		Capacity (MBH)		Capacity (MBH)	
			Total	Sen.	Total	Sen.	Total	Sen.	Total	Sen.	Total	Sen.
7T	1400	50	44.2	34.1	47.5	35	50.9	35.6	55.7	36.5	61.2	37.1
	3080	50	66.9	58.6	72.7	60.3	78.9	61.4	85.6	62	93.4	62.2
10T	1400	50	44.2	34.1	47.5	35	50.9	35.6	55.7	36.5	61.2	37.1
	3080	50	66.9	58.6	72.7	60.3	78.9	61.4	85.6	62	93.4	62.2
12T	1400	50	44.2	34.1	47.5	35	50.9	35.6	55.7	36.5	61.2	37.1
	3080	50	66.9	58.6	72.7	60.3	78.9	61.4	85.6	62	93.4	62.2
15T	2193	50	69.7	53.6	74.9	55.1	81.2	56.5	88.1	57.5	96.6	58.5
	4824	50	107.6	93	115.3	95.1	124.7	96.7	135.4	97.8	147.5	98
20T	2193	50	69.7	53.6	74.9	55.1	81.2	56.5	88.1	57.5	96.6	58.5
	4824	50	107.6	93	115.3	95.1	124.7	96.7	135.4	97.8	147.5	98
25T	2193	50	69.7	53.6	74.9	55.1	81.2	56.5	88.1	57.5	96.6	58.5
	4824	50	107.6	93	115.3	95.1	124.7	96.7	135.4	97.8	147.5	98
30T	2957	50	93.8	72.1	100.9	74.3	109.6	76.2	118.6	77.5	130	78.7
	6505	50	145	125.3	155	128	167.8	130.3	182.1	131.7	198.4	131.9
35T	2957	50	93.8	72.1	100.9	74.3	109.6	76.2	118.6	77.5	130	78.7
	6505	50	145	125.3	155	128	167.8	130.3	182.1	131.7	198.4	131.9
40T	6023	50	192.2	147.4	207	151.9	222.2	154.8	241.9	158	264.6	160.3
	13250	50	292.6	254.1	317.6	261.4	344.7	266.5	374.1	269.5	406.4	269.5
45T	6023	50	192.2	147.4	207	151.9	222.2	154.8	241.9	158	264.6	160.3
	13250	50	292.6	254.1	317.6	261.4	344.7	266.5	374.1	269.5	406.4	269.5

# PERFORMANCE DATA TABLES

Model (STANDARD)	Air Flow Rate (CFM)	RH%	Condenser Ambient Temperature [F]									
			85		95		105		115		125	
			Capacity (MBH)		Capacity (MBH)		Capacity (MBH)		Capacity (MBH)		Capacity (MBH)	
			Total	Sen.	Total	Sen.	Total	Sen.	Total	Sen.	Total	Sen.
50T	6023	50	192.2	147.4	207	151.9	222.2	154.8	241.9	158	264.6	160.3
	13250	50	292.6	254.1	317.6	261.4	344.7	266.5	374.1	269.5	406.4	269.5
55T	9673	50	309.9	237.3	332	243.7	355.9	248.2	380.6	250.5	418.4	254.7
	21281	50	467	406.9	489.2	411.5	542.8	423.7	598.1	431.7	658.9	435.3
60T	9673	50	309.9	237.3	332	243.7	355.9	248.2	380.6	250.5	418.4	254.7
	21281	50	467	406.9	489.2	411.5	542.8	423.7	598.1	431.7	658.9	435.3
65T	9673	50	309.9	237.3	332	243.7	355.9	248.2	380.6	250.5	418.4	254.7
	21281	50	467	406.9	489.2	411.5	542.8	423.7	598.1	431.7	658.9	435.3
70T	9673	50	309.9	237.3	332	243.7	355.9	248.2	380.6	250.5	418.4	254.7
	21281	50	467	406.9	489.2	411.5	542.8	423.7	598.1	431.7	658.9	435.3
80T	12046	50	384.4	294.8	414	303.8	444.4	309.6	483.8	316	529.2	320.6
	26500	50	585.2	508.2	635.2	522.8	689.4	533	748.2	539	812.8	539
90T	12046	50	384.4	294.8	414	303.8	444.4	309.6	483.8	316	529.2	320.6
	26500	50	585.2	508.2	635.2	522.8	689.4	533	748.2	539	812.8	539
100T	12046	50	384.4	294.8	414	303.8	444.4	309.6	483.8	316	529.2	320.6
	26500	50	585.2	508.2	635.2	522.8	689.4	533	748.2	539	812.8	539
110T	19346	50	619.8	474.6	664	487.4	711.8	496.4	761.2	501	836.8	509.4
	42562	50	934	813.8	978.4	823	1085.6	847.4	1196.2	863.4	1317.8	870.6
120T	19346	50	619.8	474.6	664	487.4	711.8	496.4	761.2	501	836.8	509.4
	42562	50	934	813.8	978.4	823	1085.6	847.4	1196.2	863.4	1317.8	870.6

# UNIT ELECTRICAL DATA

R134a HIGH EFFICIENT											
MODEL	POWER SUPPLY	VOLTAGE RANGE		FM	COMPRESSOR			BLOWER MOTOR		MCA	MOCP
	(V-PH-HZ)	MIN.	MAX.	FLA	RLA	LRA	KW	FLA			
7T	415/3/50	380	420			118	1.1	3.90			
10T	415/3/50	380	420			111	2.5	6.34			
12T	415/3/50	380	420			118	2.5	6.34			
15T	415/3/50	380	420			140	2.5	6.34			
20T	415/3/50	380	420			174	2.5	6.34			
25T	415/3/50	380	420			118	3.5	8.90			
30T	415/3/50	380	420			140	3.5	8.90			
35T	415/3/50	380	420			174	4.4	10.20			
40T	415/3/50	380	420			118	4.4	10.20			
45T	415/3/50	380	420			140	4.4	10.20			
50T	415/3/50	380	420			174	4.4	10.20			
55T	415/3/50	380	420			140	3.5	8.90			
60T	415/3/50	380	420			140	3.5	8.90			
65T	415/3/50	380	420			140	3.5	8.90			
70T	415/3/50	380	420			174	3.5	8.90			
80T	415/3/50	380	420			118	4.4	10.20			
90T	415/3/50	380	420			140	4.4	10.20			
100T	415/3/50	380	420			140	4.4	10.20			
110T	415/3/50	380	420			174	4.4	10.20			
120T	415/3/50	380	420			174	4.4	10.20			
R134a STANDARD											
MODEL	POWER SUPPLY	VOLTAGE RANGE		FM	COMPRESSOR			BLOWER MOTOR		MCA	MOCP
	(V-PH-HZ)	MIN.	MAX.	FLA	RLA	LRA	KW	FLA			
7T	415/3/50	380	420			140	1.1	3.90			
10T	415/3/50	380	420			111	1.1	3.90			
12T	415/3/50	380	420			118	1.1	3.90			
15T	415/3/50	380	420			174	2.5	6.34			
20T	415/3/50	380	420			118	2.5	6.34			
25T	415/3/50	380	420			118	2.5	6.34			
30T	415/3/50	380	420			140	2.5	6.34			
35T	415/3/50	380	420			174	2.5	6.34			
40T	415/3/50	380	420			140	3.5	8.90			
45T	415/3/50	380	420			174	3.5	8.90			
50T	415/3/50	380	420			174	3.5	8.90			
55T	415/3/50	380	420			140	4.4	10.20			
60T	415/3/50	380	420			174	4.4	10.20			
65T	415/3/50	380	420			174	4.4	10.20			
70T	415/3/50	380	420			140	4.4	10.20			
80T	415/3/50	380	420			140	3.5	8.90			
90T	415/3/50	380	420			174	3.5	8.90			
100T	415/3/50	380	420			174	3.5	8.90			
110T	415/3/50	380	420			140	3.5	8.90			
120T	415/3/50	380	420			174	4.4	10.20			

## LEGEND:

- FLA : Full Load Amps
- RLA : Rated Load Amps
- LRA : Locked Rotor Amps
- MCA : Minimum Circuit Amps
- MOCP : Maximum Over Current Protection



# SUPPLY AIR PERFORMANCE

## Belt Drive System

R134a HIGH EFFICIENT					
MODEL	CFM	Min External (in.WG)	Max External (in.WG)	Motor (RPM)	Motor (KW)
7T	1400	0.125	0.5	450	0.28
	3080	0.125	0.5	900	1.1
10T	2193	0.125	0.5	450	0.66
	4824	0.125	0.5	900	2.5
12T	2193	0.125	0.5	450	0.66
	4824	0.125	0.5	900	2.5
15T	2193	0.125	0.5	450	0.66
	4824	0.125	0.5	900	2.5
20T	2957	0.125	0.5	400	0.66
	6505	0.125	0.5	800	2.5
25T	6023	0.125	0.5	400	1.8
	13250	0.125	0.5	800	7
30T	6023	0.125	0.5	400	1.8
	13250	0.125	0.5	800	7
35T	9673	0.125	0.5	350	2.2
	21281	0.125	0.5	700	8.8
40T	9673	0.125	0.5	350	2.2
	21281	0.125	0.5	700	8.8
45T	9673	0.125	0.5	350	2.2
	21281	0.125	0.5	700	8.8
50T	9673	0.125	0.5	350	2.2
	21281	0.125	0.5	700	8.8
55T	12046	0.125	0.5	400	3.6
	26500	0.125	0.5	800	14
60T	12046	0.125	0.5	400	3.6
	26500	0.125	0.5	800	14
65T	12046	0.125	0.5	400	3.6
	26500	0.125	0.5	800	14
70T	12046	0.125	0.5	400	3.6
	26500	0.125	0.5	800	14
80T	19346	0.125	0.5	350	4.4
	42562	0.125	0.5	700	17.6
90T	19346	0.125	0.5	350	4.4
	42562	0.125	0.5	700	17.6
100T	19346	0.125	0.5	350	4.4
	42562	0.125	0.5	700	17.6
110T	19346	0.125	0.5	350	4.4
	42562	0.125	0.5	700	17.6
120T	19346	0.125	0.5	350	4.4
	42562	0.125	0.5	700	17.6

R134a STANDARD					
MODEL	CFM	Min External (in.WG)	Max External (in.WG)	Motor (RPM)	Motor (KW)
7T	1400	0.125	0.5	450	0.28
	3080	0.125	0.5	900	1.1
10T	1400	0.125	0.5	450	0.28
	3080	0.125	0.5	900	1.1
12T	1400	0.125	0.5	450	0.28
	3080	0.125	0.5	900	1.1
15T	2193	0.125	0.5	450	0.66
	4824	0.125	0.5	900	2.5
20T	2193	0.125	0.5	450	0.66
	4824	0.125	0.5	900	2.5
25T	2193	0.125	0.5	450	0.66
	4824	0.125	0.5	900	2.5
30T	2957	0.125	0.5	400	0.66
	6505	0.125	0.5	800	2.5
35T	2957	0.125	0.5	400	0.66
	6505	0.125	0.5	800	2.5
40T	6023	0.125	0.5	400	1.8
	13250	0.125	0.5	800	7
45T	6023	0.125	0.5	400	1.8
	13250	0.125	0.5	800	7
50T	6023	0.125	0.5	400	1.8
	13250	0.125	0.5	800	7
55T	9673	0.125	0.5	350	2.2
	21281	0.125	0.5	700	8.8
60T	9673	0.125	0.5	350	2.2
	21281	0.125	0.5	700	8.8
65T	9673	0.125	0.5	350	2.2
	21281	0.125	0.5	700	8.8
70T	9673	0.125	0.5	350	2.2
	21281	0.125	0.5	700	8.8
80T	12046	0.125	0.5	400	3.6
	26500	0.125	0.5	800	14
90T	12046	0.125	0.5	400	3.6
	26500	0.125	0.5	800	14
100T	12046	0.125	0.5	400	3.6
	26500	0.125	0.5	800	14
110T	12046	0.125	0.5	400	3.6
	26500	0.125	0.5	800	14
120T		0.125	0.5	350	4.4
	42562	0.125	0.5	700	17.6

# UNIT DIMENSIONS

10 T

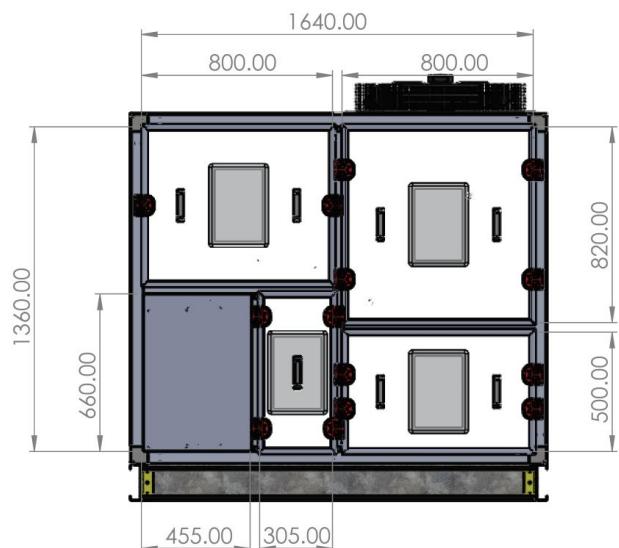
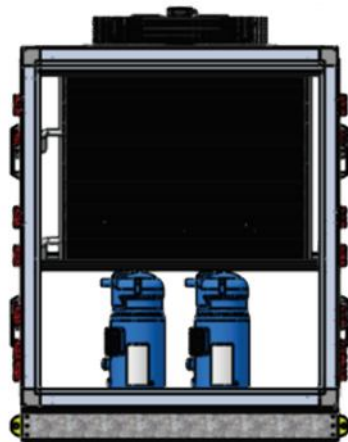
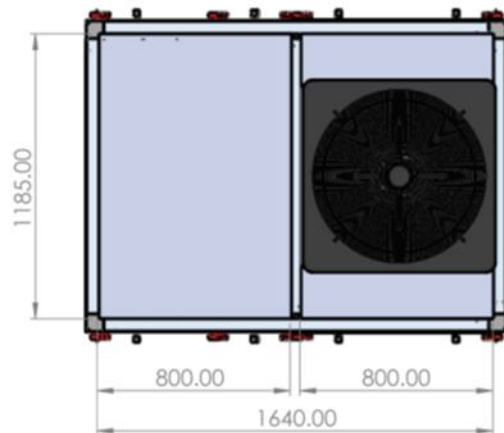
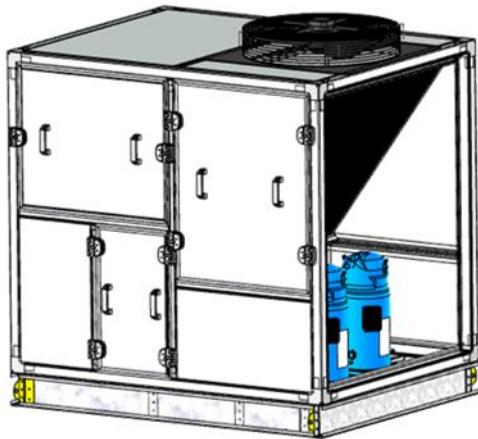

# UNIT DIMENSIONS

20 T

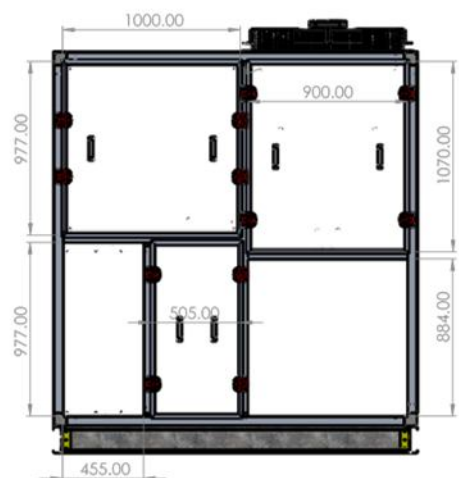
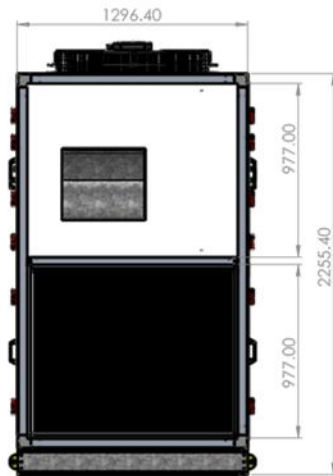
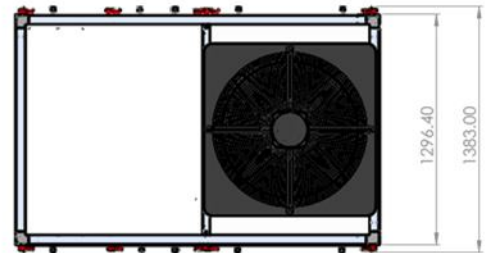
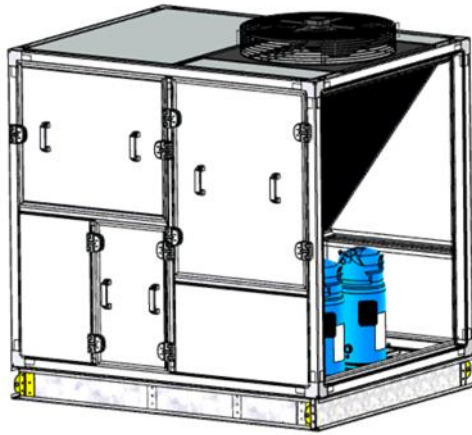

# UNIT DIMENSIONS

30 T

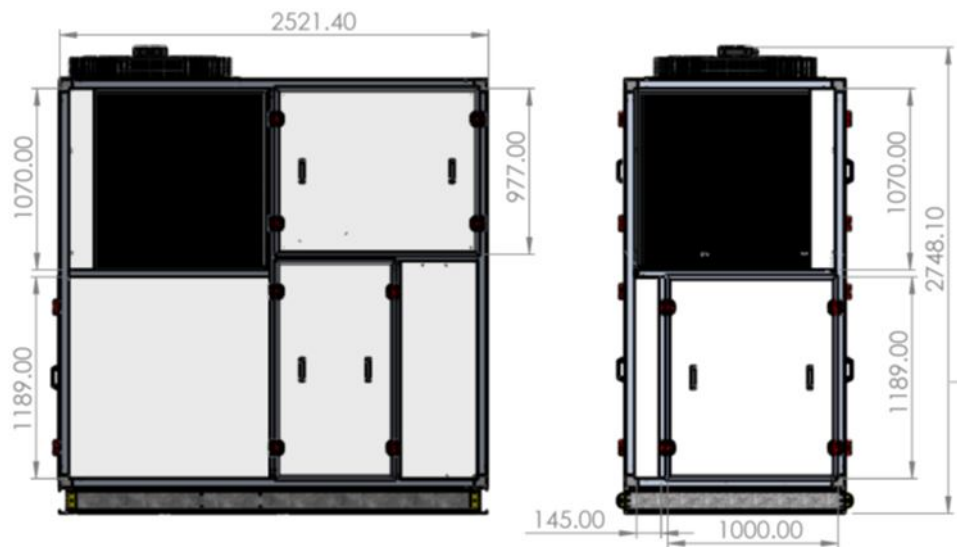
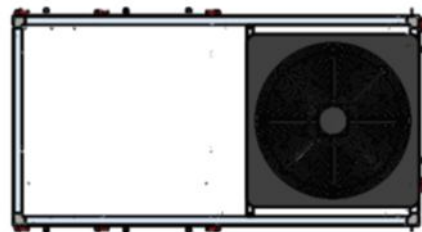
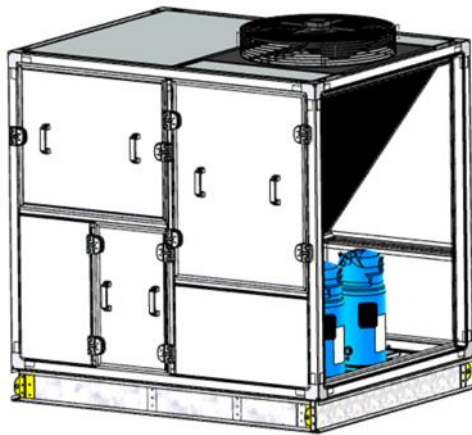



# UNIT DIMENSIONS

40 T

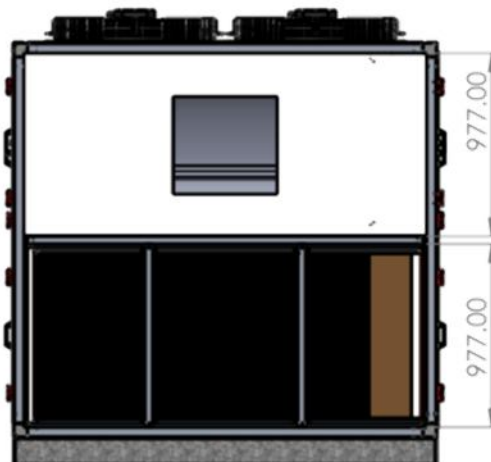
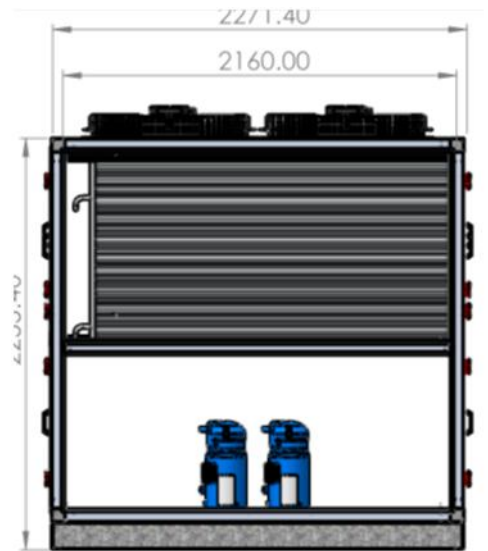
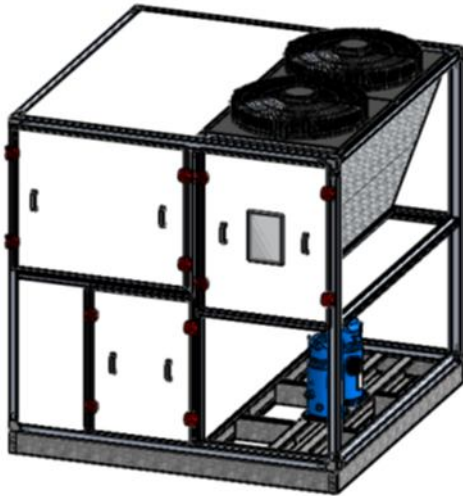

# UNIT DIMENSIONS

60 T

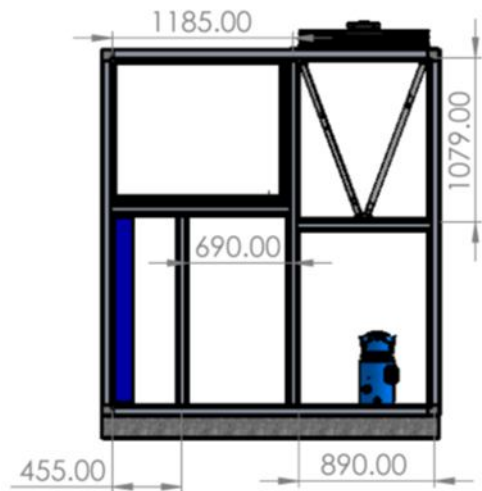
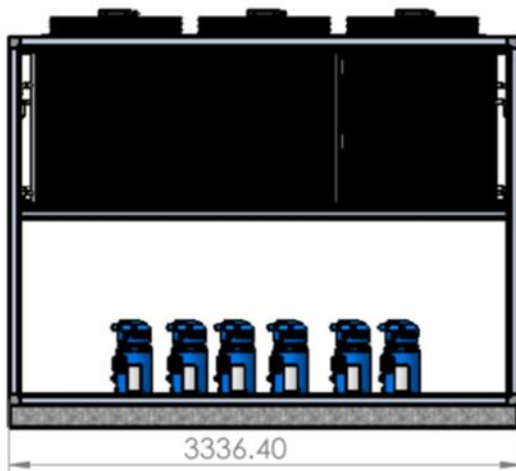
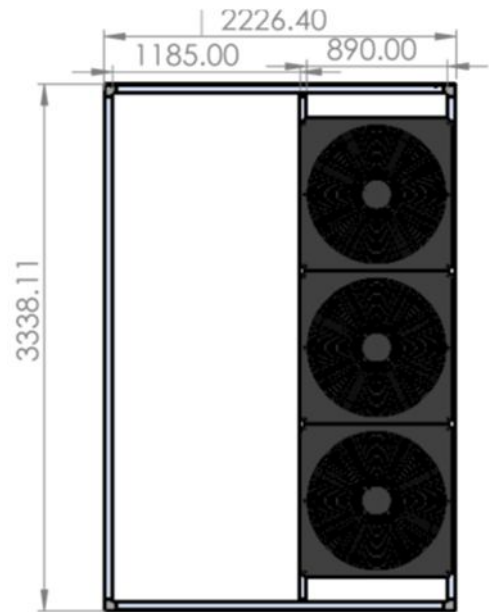
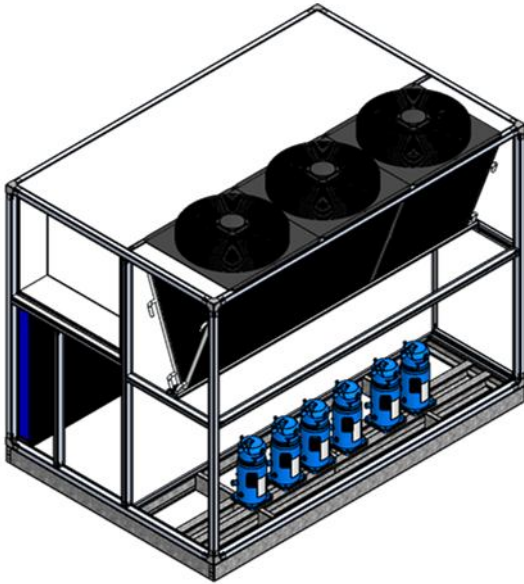

# UNIT DIMENSIONS

Package Filter

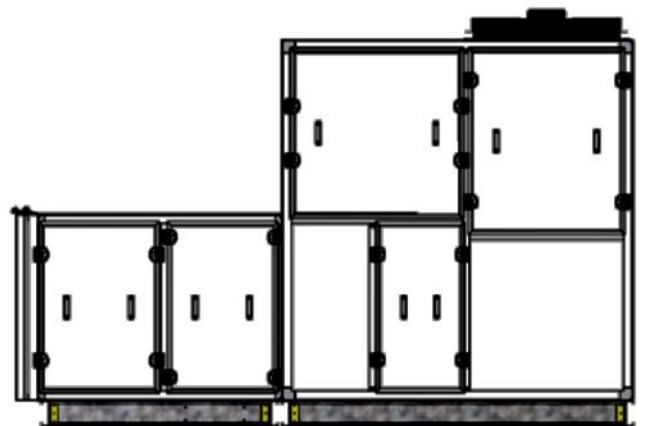
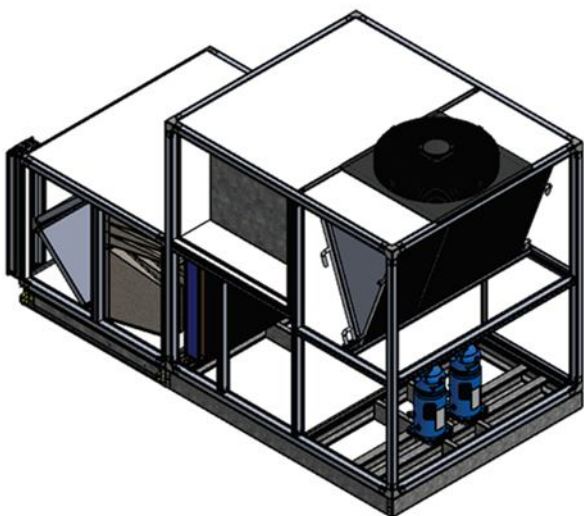
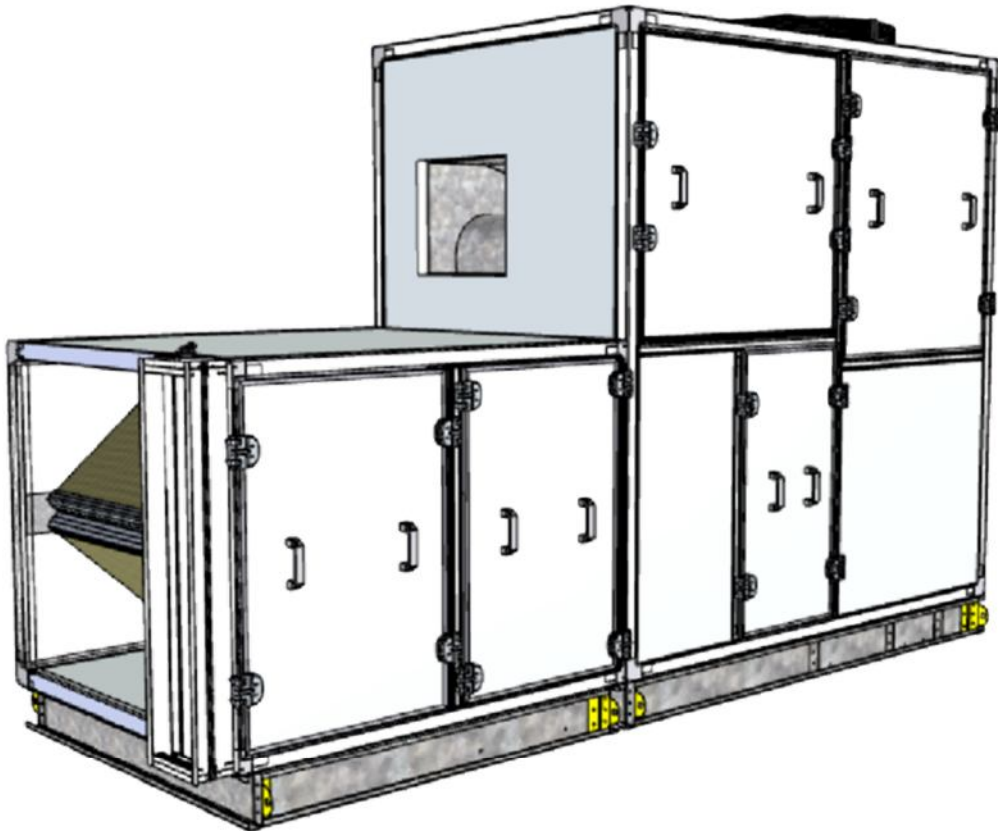







# . NOTE .

A large rectangular area with rounded corners, outlined in light blue, containing numerous horizontal light blue lines for writing. The lines are evenly spaced and cover the majority of the page below the header.



**ECO COOLER**  
AIR CONDITIONER